

**DynaDoctor V**  
**Operation Manual**

Ver. 1.2

19 July 2016

**– CONTENTS –**

<b>1. OVERVIEW</b> .....	<b>4</b>
<b>2. OPERATING ENVIRONMENT</b> .....	<b>4</b>
<b>3. DYNADOCTOR V BASIC OPERATION</b> .....	<b>5</b>
3.1. DYNADOCTOR V FUNCTIONS .....	5
3.2. STARTING/EXITING DYNADOCTOR V.....	9
<b>4. USING DYNADOCTOR V</b> .....	<b>11</b>
4.1. DISPLAYING DATA .....	11
4.2. SAVING RECEIVED DATA.....	13
4.3. BROWSING SAVED DATA.....	14
4.4. EDITING DATA FILES.....	15
4.5. COMMUNICATION SETTINGS .....	16
4.6. PRINTING OUT THE SCREEN .....	17
4.7. FINISHING COMMUNICATING/BROWSING.....	18
4.8. MANAGING THE WINDOWS .....	19
<b>5. REFRIGERANT CYCLE DIAGRAMS</b> .....	<b>22</b>
5.1. DISPLAYING A SYSTEM CONFIGURATION DIAGRAM (COMMUNICATION).....	22
5.2. DISPLAYING A SYSTEM CONFIGURATION DIAGRAM (REFRIGERANT CYCLE) .....	23
5.3. DISPLAYING A REFRIGERANT CYCLE DIAGRAM (SYSTEM DATA) .....	24
5.4. DISPLAYING LIST DATA/SYSTEM DATA .....	26
<b>6. DISPLAYING GRAPHS</b> .....	<b>28</b>
6.1. DISPLAYING OUTDOOR UNIT GRAPHS.....	28
6.2. DISPLAYING INDOOR UNIT GRAPHS .....	30
<b>7. OTHER FUNCTIONS</b> .....	<b>35</b>
7.1. CHECKING THE LIST OF CHECK CODES.....	35
7.2. DISPLAYING A SYSTEM CONTROL DATA TABLE .....	35
7.3. CHANGING THE DISPLAYED PRESSURE DATA UNIT .....	36
7.4. CHANGING THE DISPLAYED TEMPERATURE DATA UNIT .....	37
7.5. DISPLAYING TIPS.....	37
7.6. COMPRESSING DATA .....	38
7.7. COMBINING DATA .....	39
<b>8. ON/OFF CONTROL</b> .....	<b>42</b>
8.1. EXECUTING INDOOR UNIT TEST RUNS .....	42

- 8.2. STORING OPERATION MODES ..... 44
- 8.3. RESTORING OPERATION MODE ..... 45
- 9. CREATING TEST RUN REPORTS ..... 46**
  - 9.1. OPENING THE TEST OPERATION REPORT WINDOW ..... 46
  - 9.2. CREATING REPORT DATA..... 47
  - 9.3. SEARCHING FOR REPORT DATA ..... 60
  - 9.4. DELETING REPORT DATA ..... 64
  - 9.5. PRINTING OUT REPORT DATA..... 65
- 10. TOSHIBA CARRIER SOFTWARE LICENSE AGREEMENT ..... 67**

## 1. Overview

"DynaDoctor V" analyses data sent from the Dynakit, and supports the status display of outdoor and indoor units. This tool can be used to check refrigerant cycle data, display various data graphs, execute indoor unit test runs and create reports of test run results.

Furthermore, received data can be saved and browsed, and secondary use of data can be carried out easily.

## 2. Operating Environment

The following is the ideal operating environment for this software:

Item	Specifications
PC	Windows 7 Windows 8.1 Windows 10 compliant
Operating System	Windows 7 Windows 8.1 Windows 10 compliant
Microsoft Excel	Excel 2003 or later

3. DynaDoctor V basic operation

3.1. DynaDoctor V functions

3.1.1. Check refrigerant cycle data

A refrigerant cycle data check can be performed using DynaDoctor V. This function allows for visual checking of the status of outdoor and indoor units.

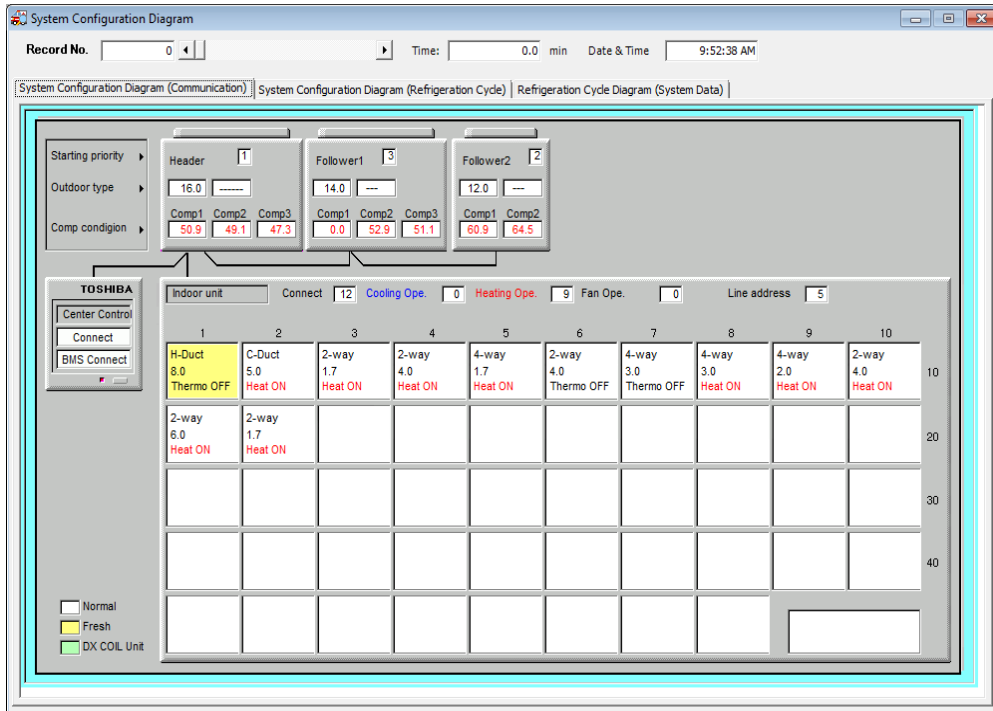
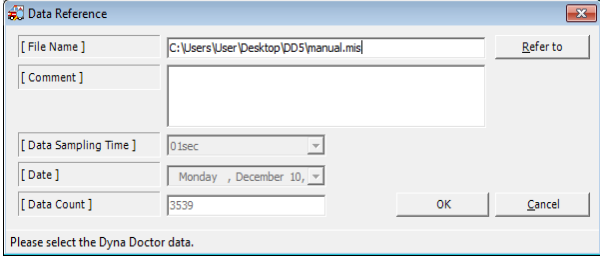


Figure 3.1.1

3.1.2. Save/browse data

Data communicated by the Dynakit can be saved. Furthermore, this saved data can be used to check past data.



**Figure 3.1.2**

### 3.1.3. Display data graphs

Data graphs for indoor and outdoor units can be displayed using saved data. Viewing several graphs together makes it easy to compare data.

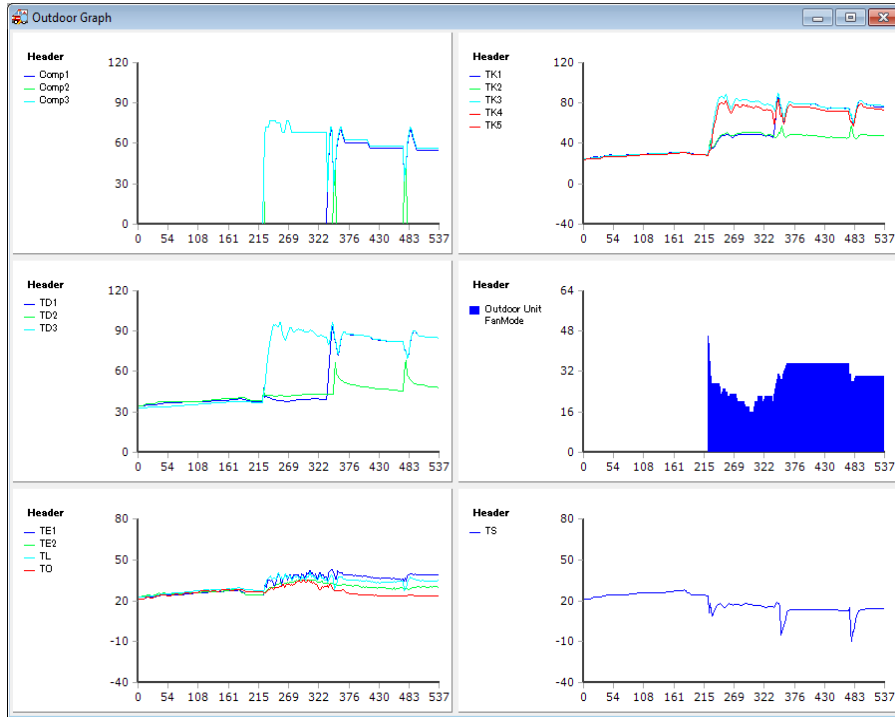


Figure 3.1.3

3.1.4. Air conditioner test runs

Test runs can be executed on connected indoor units. Furthermore, received data can be used to create reports of test run results.

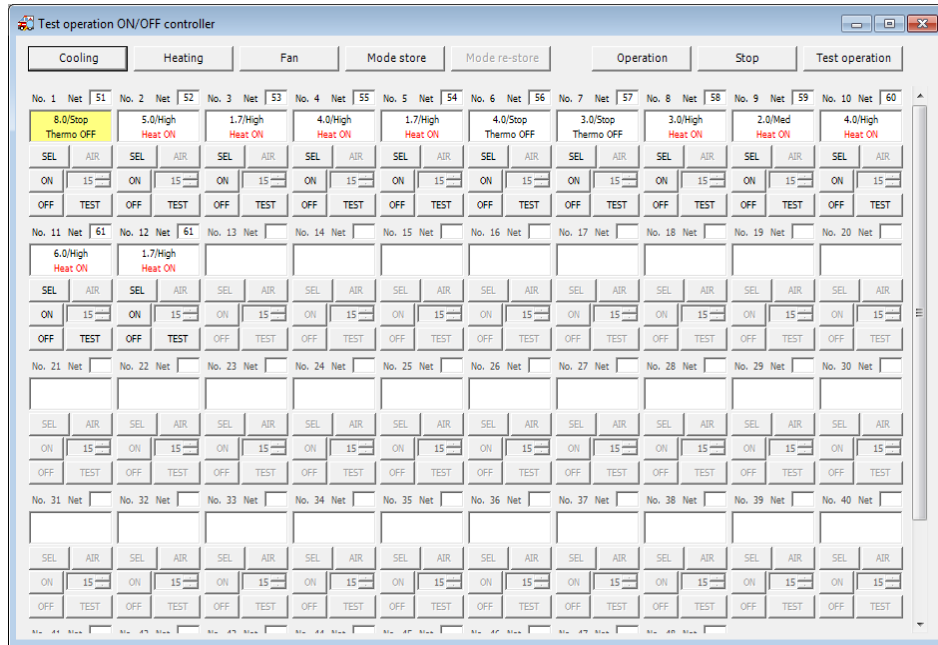


Figure 3.1.4



### 3.2. Starting/exiting DynaDoctor V

#### 3.2.1. Start-up DynaDoctor

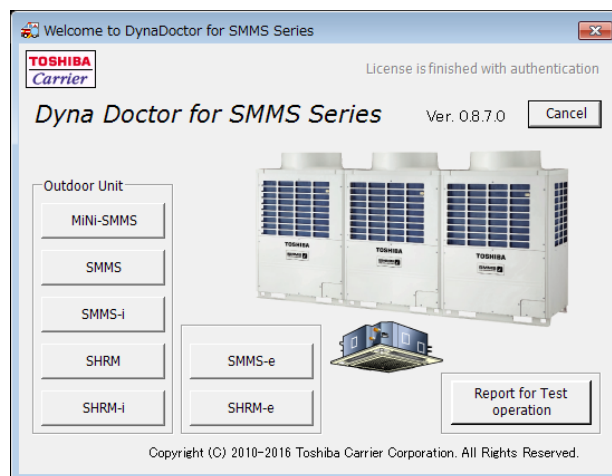
DynaDoctor V can be started up in 2 ways, using a desktop shortcut or the Windows menu.

① Start-up DynaDoctor

- Using a desktop shortcut  
Double-click the desktop shortcut.
- Using the Windows menu  
In the [Start] menu, select [All Programs] > [Toshiba] > [DynaDoctor V] > [DynaDoctor V].

② When DynaDoctor V has started-up

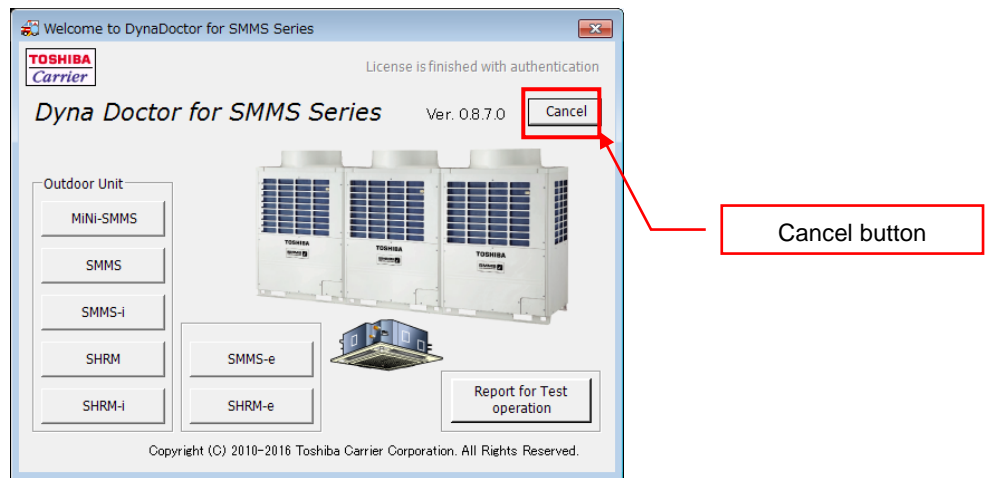
The DynaDoctor V main menu screen is displayed when DynaDoctor V has started-up. The functions can now be used.



**Figure 3.2.1**

## 3.2.2. Exiting DynaDoctor V

Click the [Cancel] button to exit DynaDoctor V.



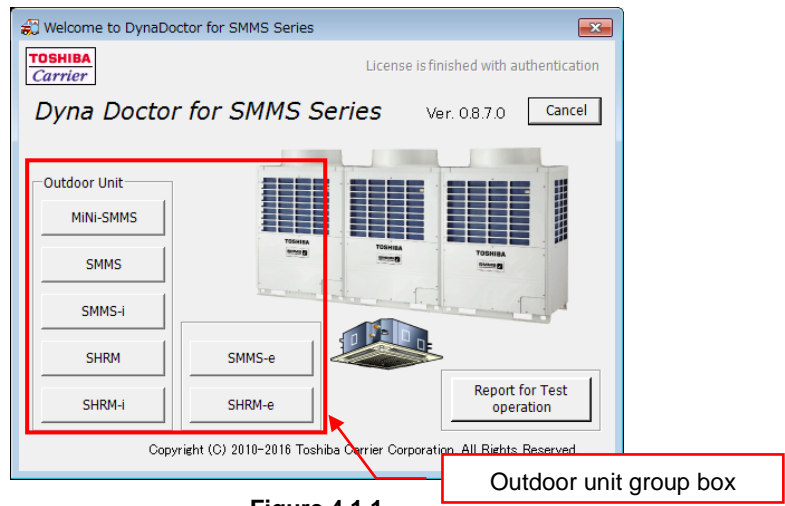
**Figure 3.2.2**

#### 4. Using DynaDoctor V

DynaDoctor V uses an MDI window. Each window is displayed inside the MDI window.

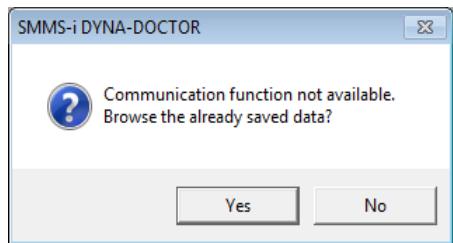
##### 4.1. Displaying data

Choose the button for the connected model from the [Outdoor unit] group box.



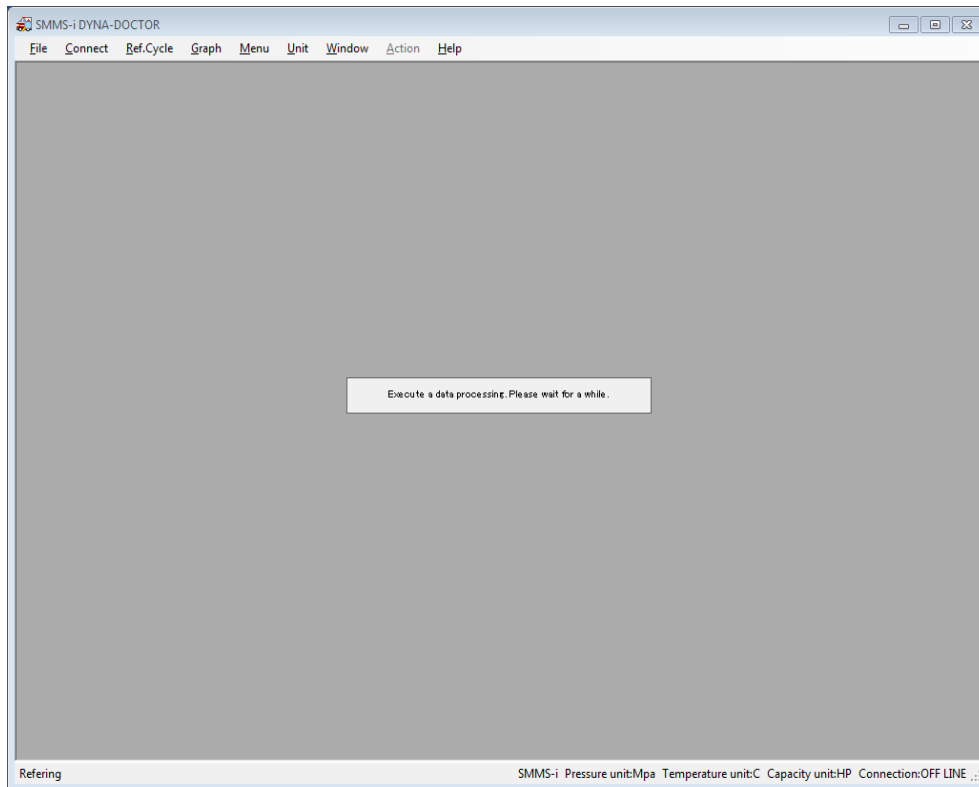
**Figure 4.1.1**

The MDI parent window opens. If the communication function is unavailable, a message is displayed. Choose [Yes] to open the window. Choose [No] to return to the main menu.



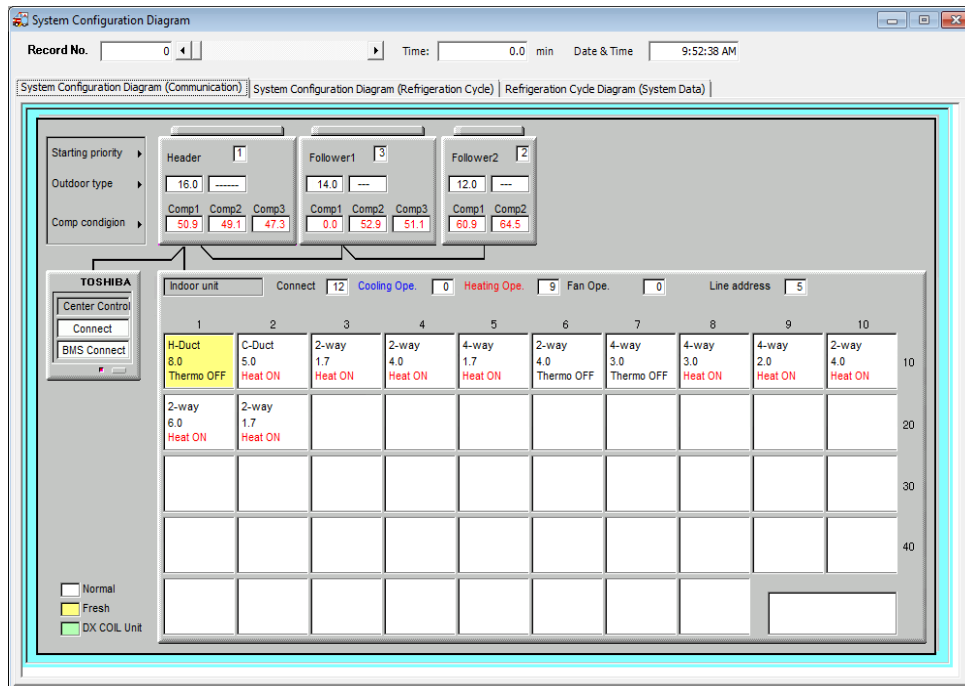
**Figure 4.1.2**

When communication is possible, or when browsing data, a wait screen is displayed while the screen renders.



**Figure 4.1.3**

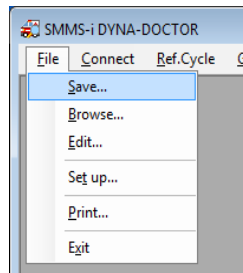
When the screen has been rendered, a system configuration diagram window opens.



**Figure 4.1.4**

#### 4.2. Saving received data

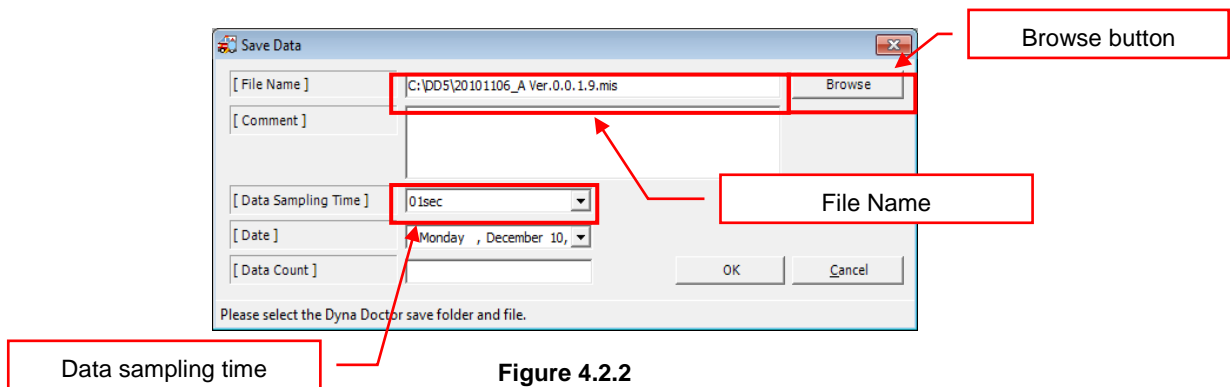
To save communication data, select [Save...] from the [File] menu. A save window opens.



**Figure 4.2.1**

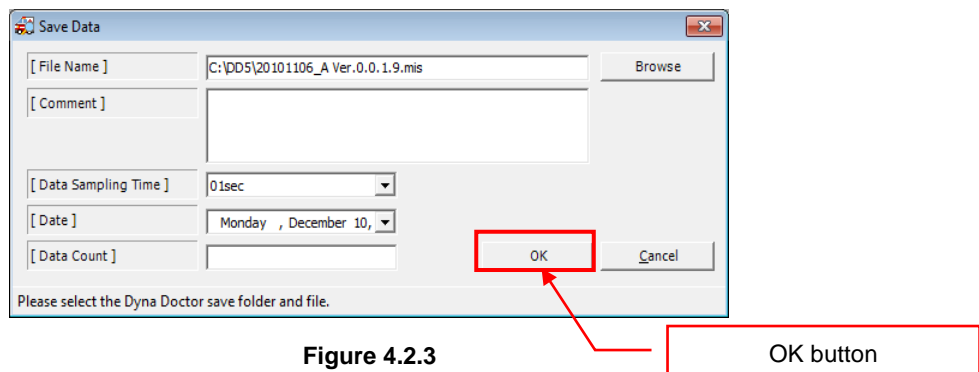
To choose the save destination, click the [Browse] button. A save file dialogue is displayed. Choose a save destination. The destination file path is displayed in the window.

Change the [Data Sampling Time] to alter the frequency with which data is saved to the file. Comments can also be added to files.



**Figure 4.2.2**

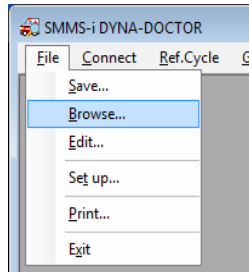
Click the [OK] button to start saving data to the file.



**Figure 4.2.3**

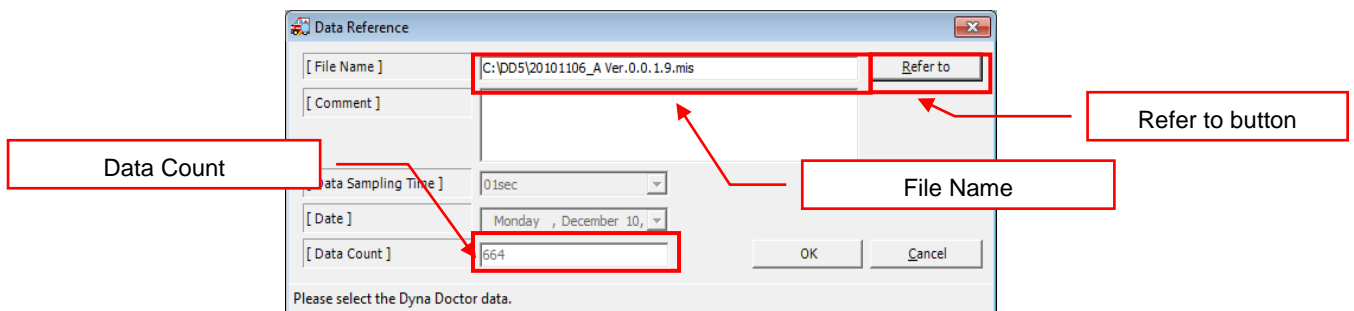
### 4.3. Browsing saved data

Data saved in [Saving received data](#) can be browsed. To browse data, choose [Browse...] from the [File] menu. A file browsing window opens.



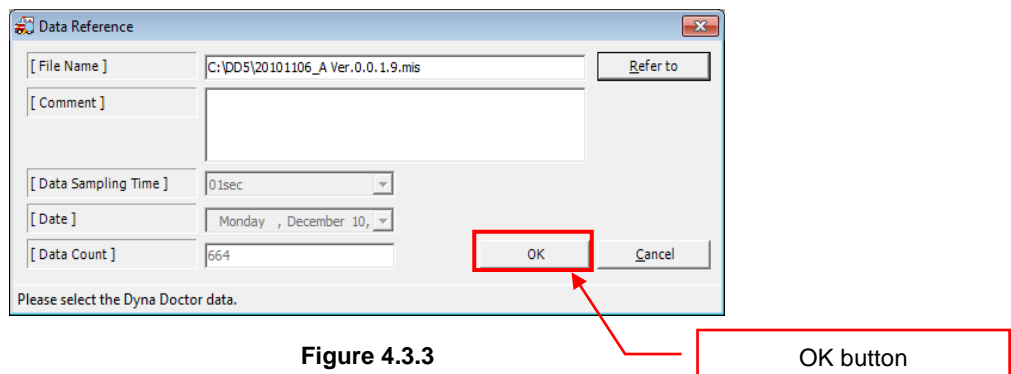
**Figure 4.3.1**

Click the [Refer to] button to select which data to browse. An open file dialogue is displayed. Select a file. The destination file path, save date and data count are displayed on the screen. If there are any comments attached to the file, they are also displayed.



**Figure 4.3.2**

Click the [OK] button to start browsing the file.



**Figure 4.3.3**

When browsing files, [Record No.], a scroll bar, [Time] (time elapsed since the first piece of data was saved) and [Date & Time] (time that data was received) are displayed.

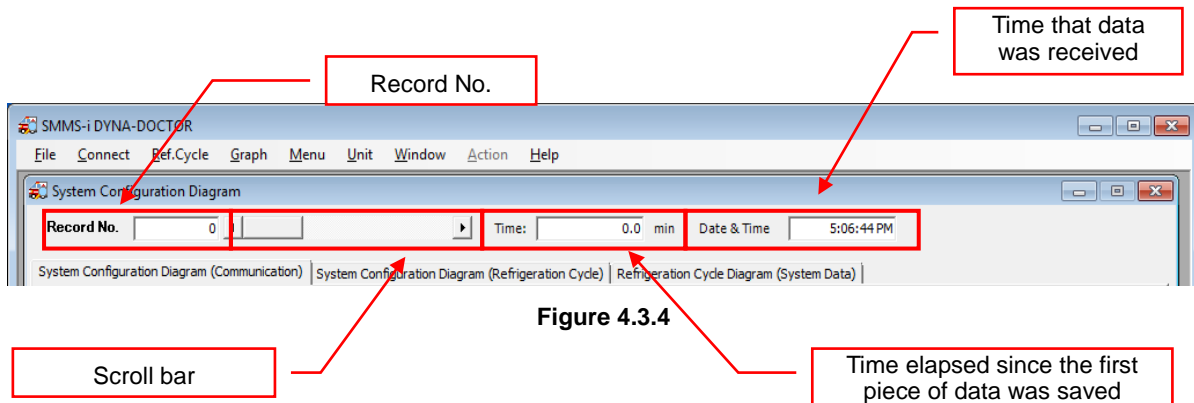


Figure 4.3.4

Move the scroll bar to change the data being displayed. A number can also be entered directly into Record No. to change the displayed data.

#### 4.4. Editing data files

File comments saved in [Saving received data](#) can be edited. To edit comments choose [Edit...] from the [File] menu. A file edit window opens.

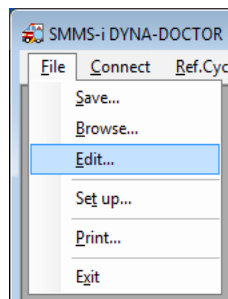
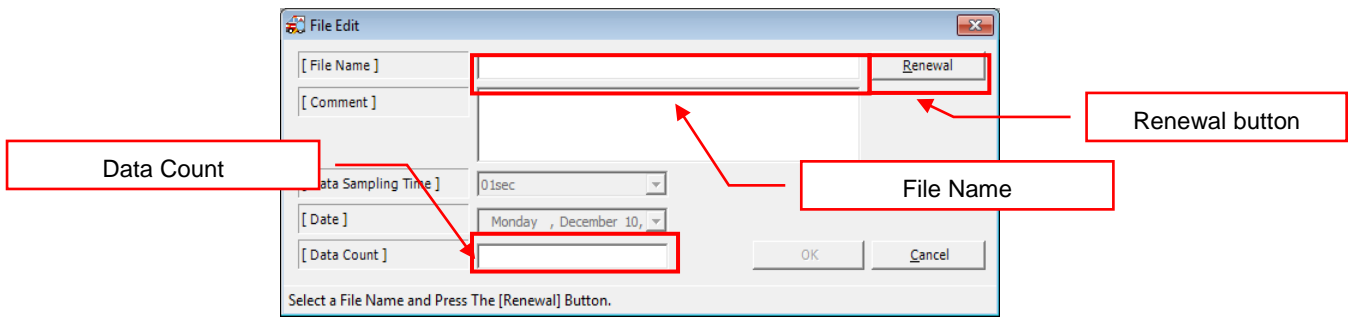


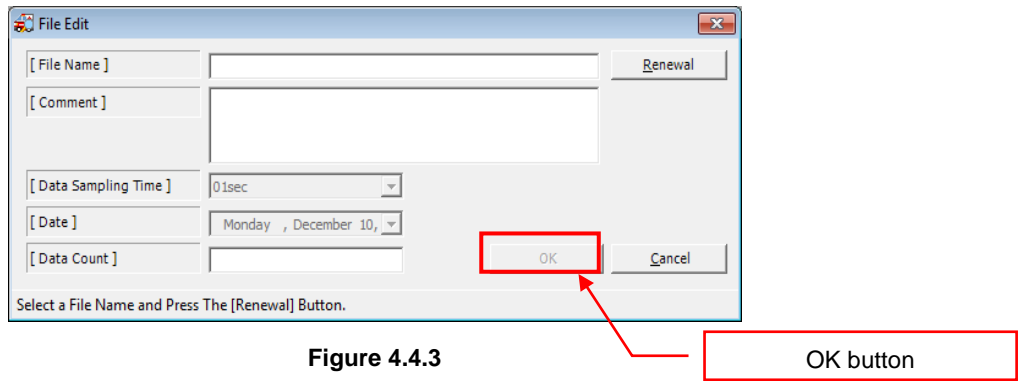
Figure 4.4.1

Click the [Renewal] button to select which data to edit. An open file dialogue is displayed. Select a file. The destination file path, save date and data count are displayed on the screen. If there are any comments attached to the file, they are also displayed.



**Figure 4.4.2**

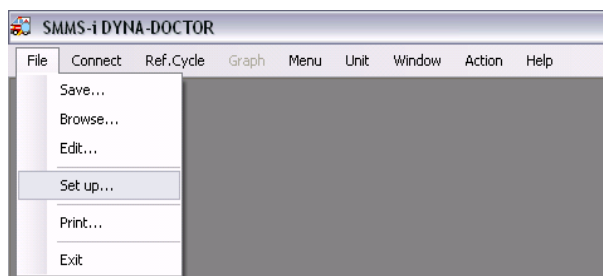
Click the [OK] button to save the edited comments.



**Figure 4.4.3**

#### 4.5. Communication settings

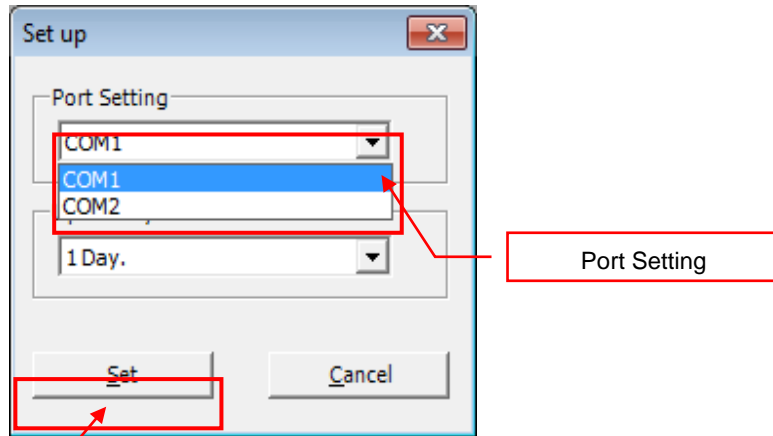
Communication settings can be changed. To open the communication settings window, select [Set up...] from the [File] menu.



**Figure 4.5.1**

The COM port on the computer which is running the system is displayed in [Port Setting]. To change the COM port used for the connection, select a COM port from the list. Press the [Set] button to change the COM port.



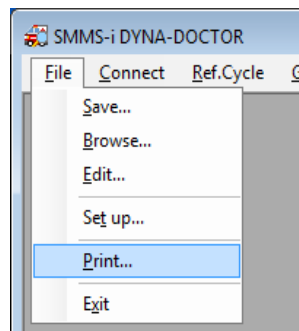


**Figure 4.5.2**

Set button

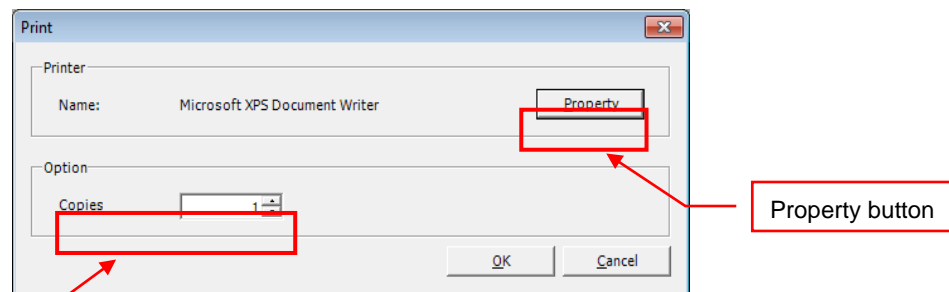
#### 4.6. Printing out the screen

The displayed screen can be printed out. To open the print settings window, select [Print...] from the [File] menu.



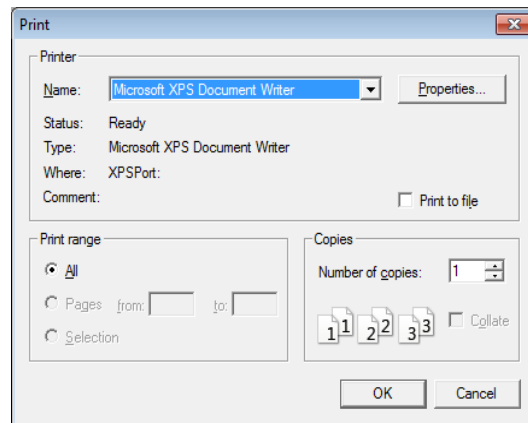
**Figure 4.6.1**

Click the [Property] button to change the printer settings. A print dialogue is displayed. The number of copies can also be input directly.



**Figure 4.6.2**

No. of copies

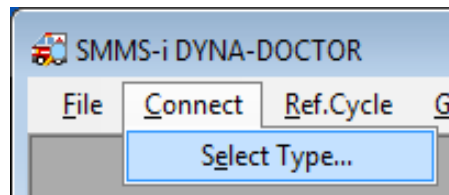


**Figure 4.6.3**

Click the [OK] button to print out the screen.

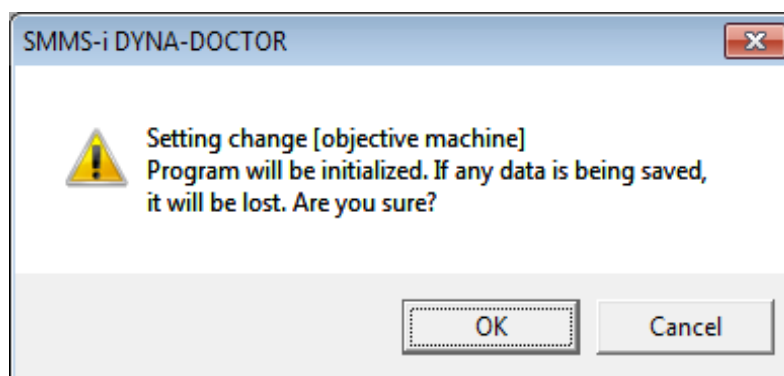
#### 4.7. Finishing communicating/browsing

To finish communicating with the outdoor unit or browsing a data file, select [Select Type...] from the [Connect] menu.



**Figure 4.7.1**

A finish confirmation message is displayed. Click [OK] to end communication/browsing and go to the main menu.



**Figure 4.7.2**

4.8. Managing the windows

Use the [Window] menu to manage the open windows.

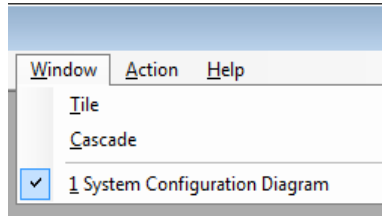


Figure 4.8.1

4.8.1. Displaying windows side by side

Choose [Tile] from the [Window] menu to display windows side by side. The open windows are automatically lined up and positioned.

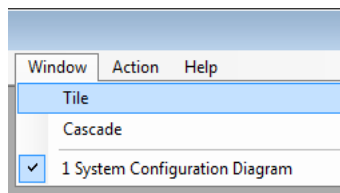


Figure 4.8.2

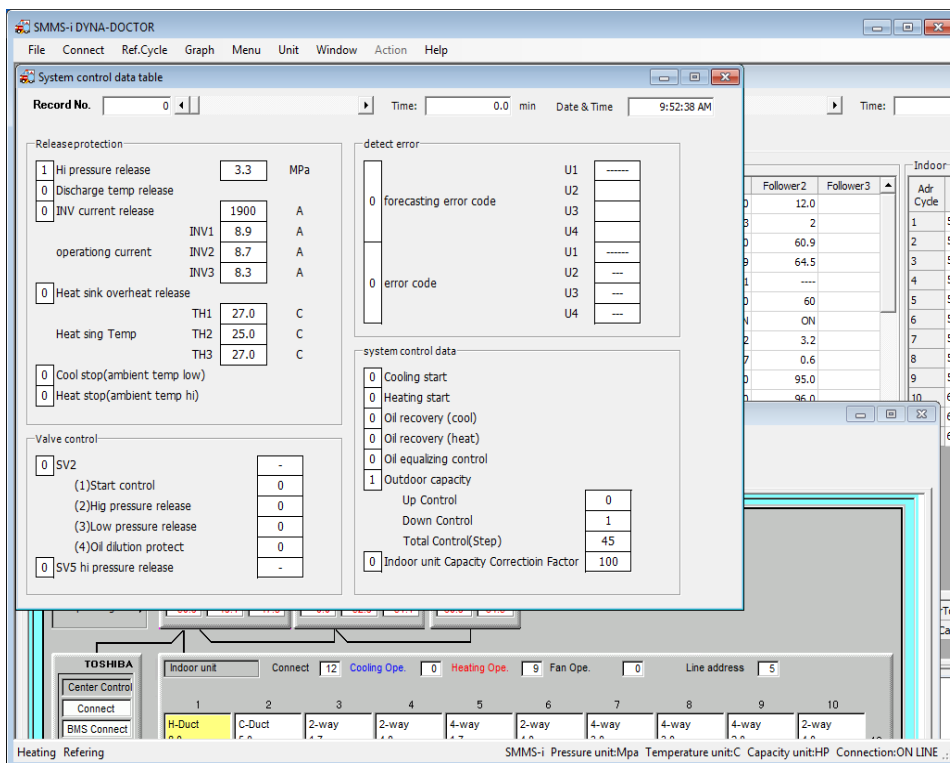
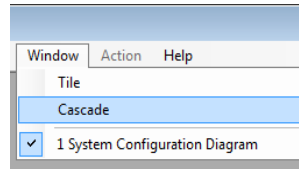


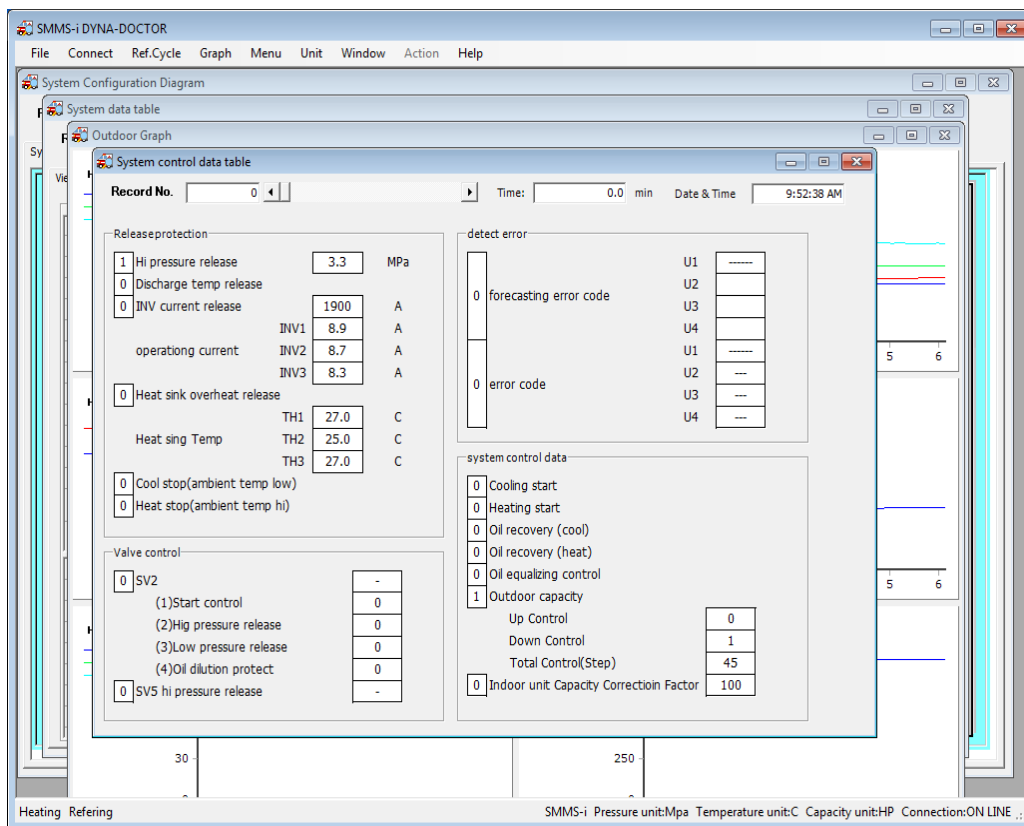
Figure 4.8.3

4.8.2. Displaying windows in a cascade

Choose [Cascade] from the [Window] menu to display windows in a cascade. The open windows are automatically stacked and positioned.



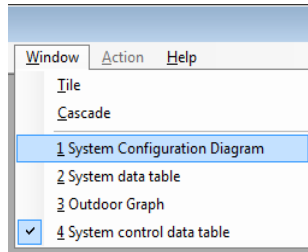
**Figure 4.8.4**



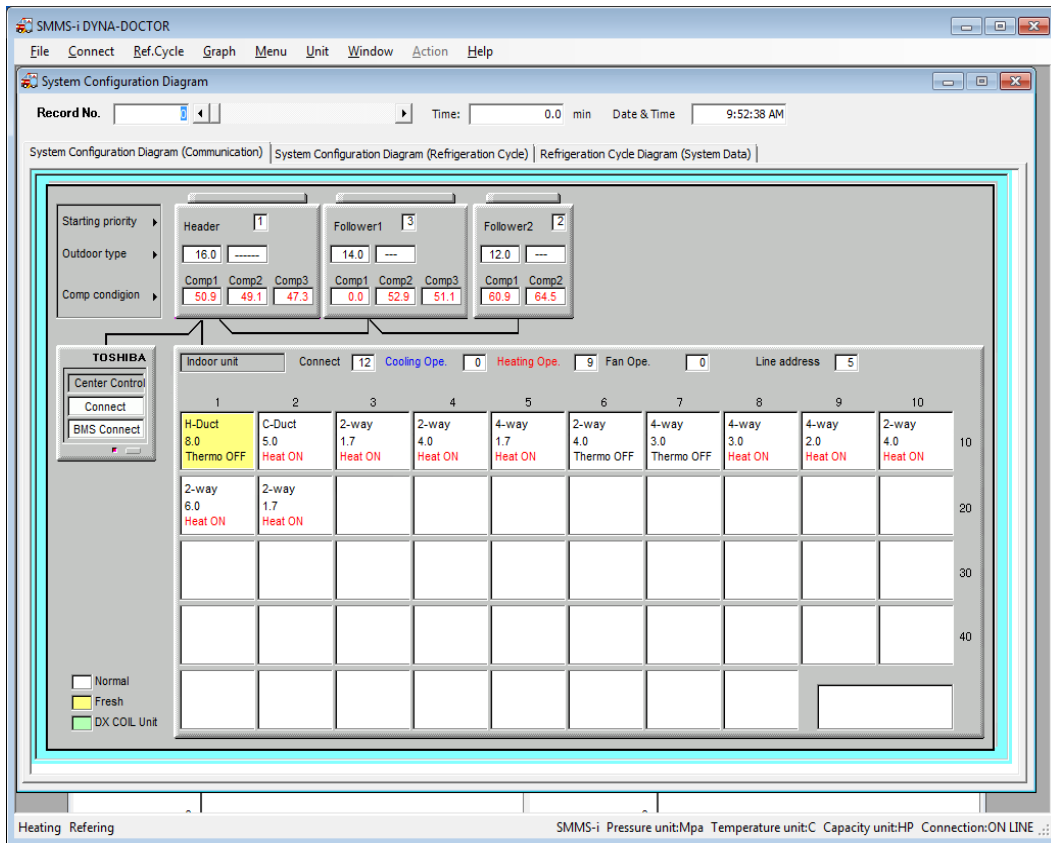
**Figure 4.8.5**

4.8.3. Displaying a specific window at the front

To display a specific window at the front, select the appropriate window from the [Window] menu. The selected window is displayed at the front.



**Figure 4.8.6**

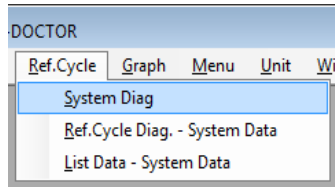


**Figure 4.8.7**

5. Refrigerant cycle diagrams

5.1. Displaying a system configuration diagram (communication)

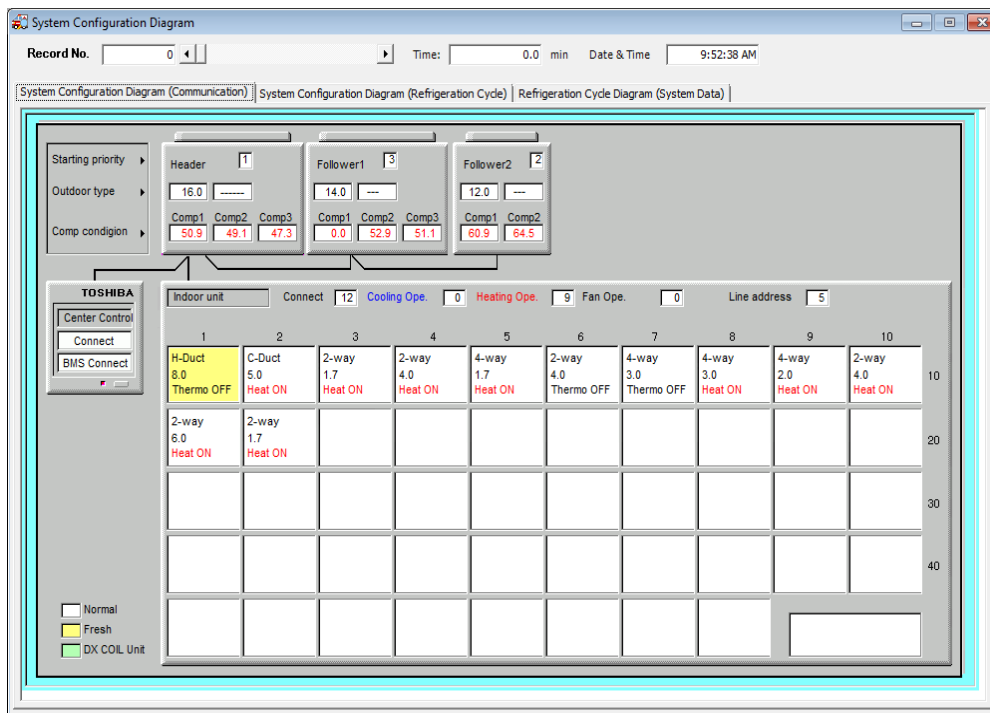
A system configuration diagram for the air conditioner currently connected or being browsed can be displayed. To display a system configuration diagram, select [System Diag] from the [Ref. Cycle] menu.



**Figure 5.1.1**

A wait screen is displayed while data is loading. The system configuration diagram is displayed when data has finished loading.

The system configuration diagram can be used to check the indoor/outdoor unit connection or operation status.



**Figure 5.1.2**

5.2. Displaying a system configuration diagram (refrigerant cycle)

The refrigerant cycle for the air conditioner currently connected or being browsed can be displayed. Refer to [Displaying a system configuration diagram \(communication\)](#) or [Displaying a refrigerant cycle diagram \(system data\)](#) for information on displaying the refrigerant cycle window.

Click the [System Configuration Diagram (Refrigeration Cycle)] tab in the system configuration diagram window to display a refrigerant cycle diagram for the whole system.

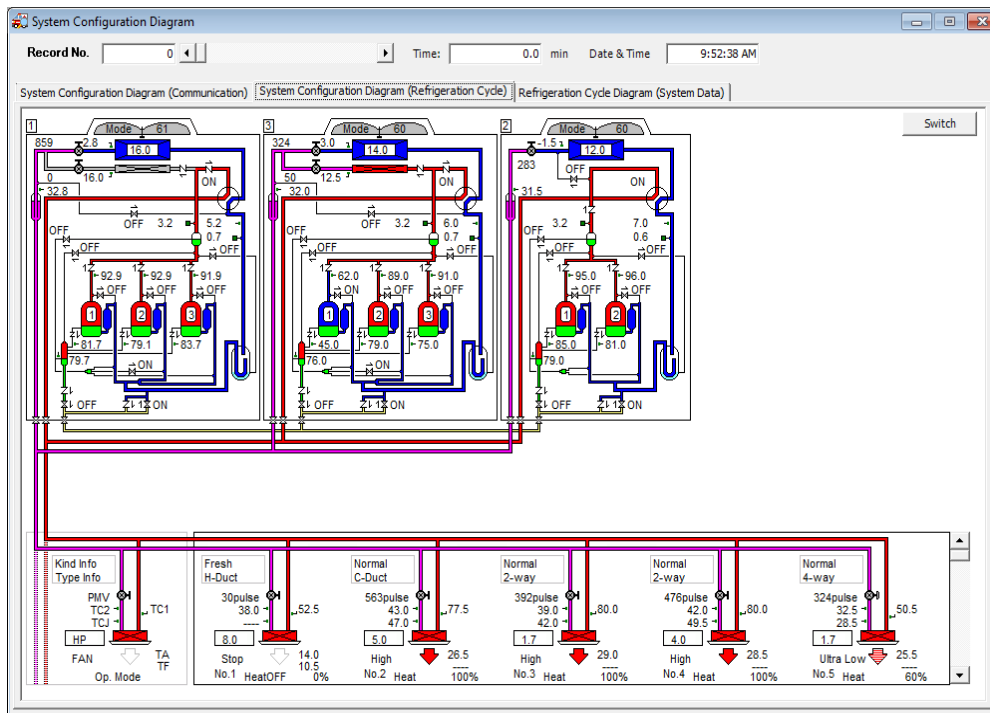
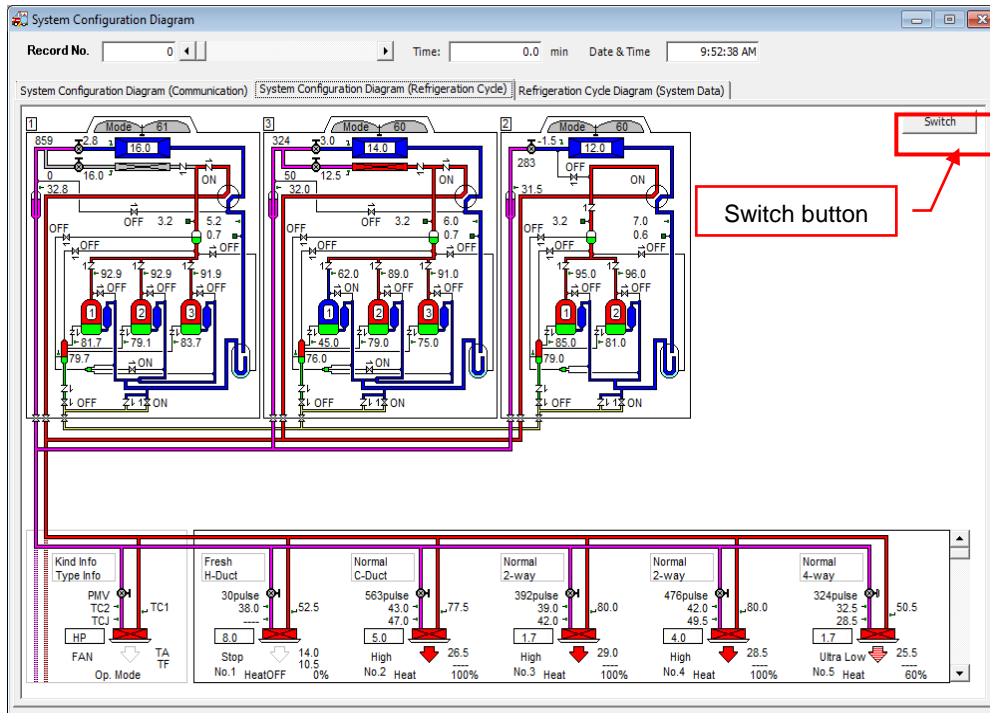


Figure 5.2.1

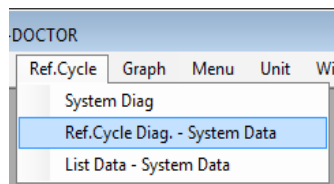
Click the [Switch] button to switch between displaying the refrigerant cycle diagram data item and the actual data. Move the [Indoor unit] scroll bar to change the indoor units being displayed (five units at a time).



**Figure 5.2.2**

### 5.3. Displaying a refrigerant cycle diagram (system data)

A refrigerant cycle diagram for each air conditioner currently connected or being browsed can be displayed. To display the refrigerant cycle diagram screen, select [Ref. Cycle Diag. - System Data] from the [Ref. Cycle] menu.

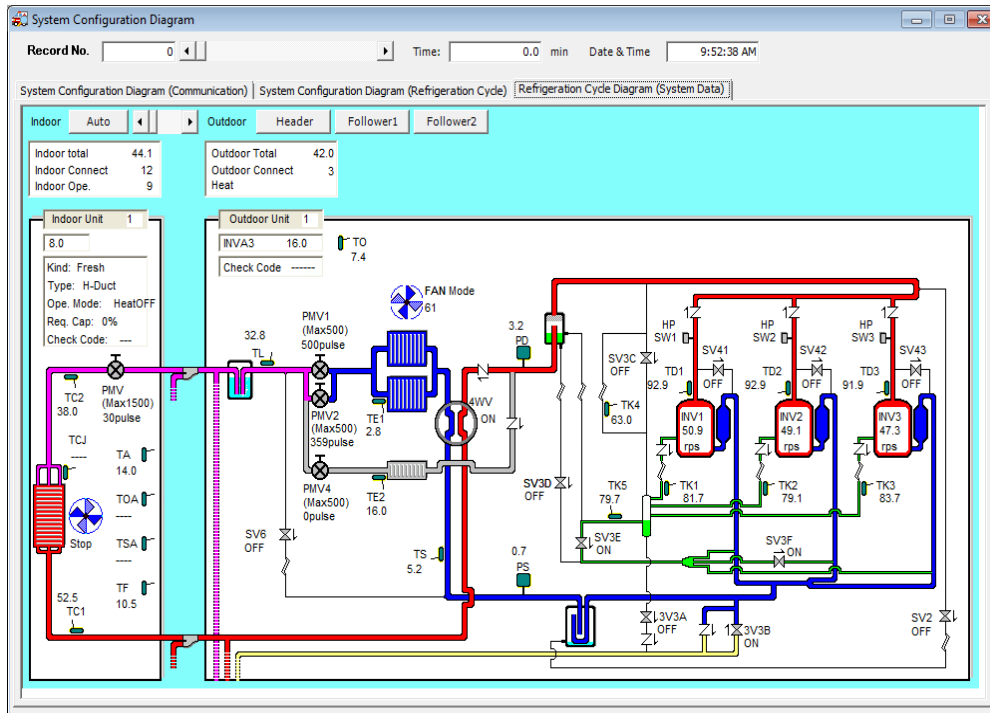


**Figure 5.3.1**

A wait screen is displayed while data is loading. The system configuration diagram is displayed when data has finished loading.

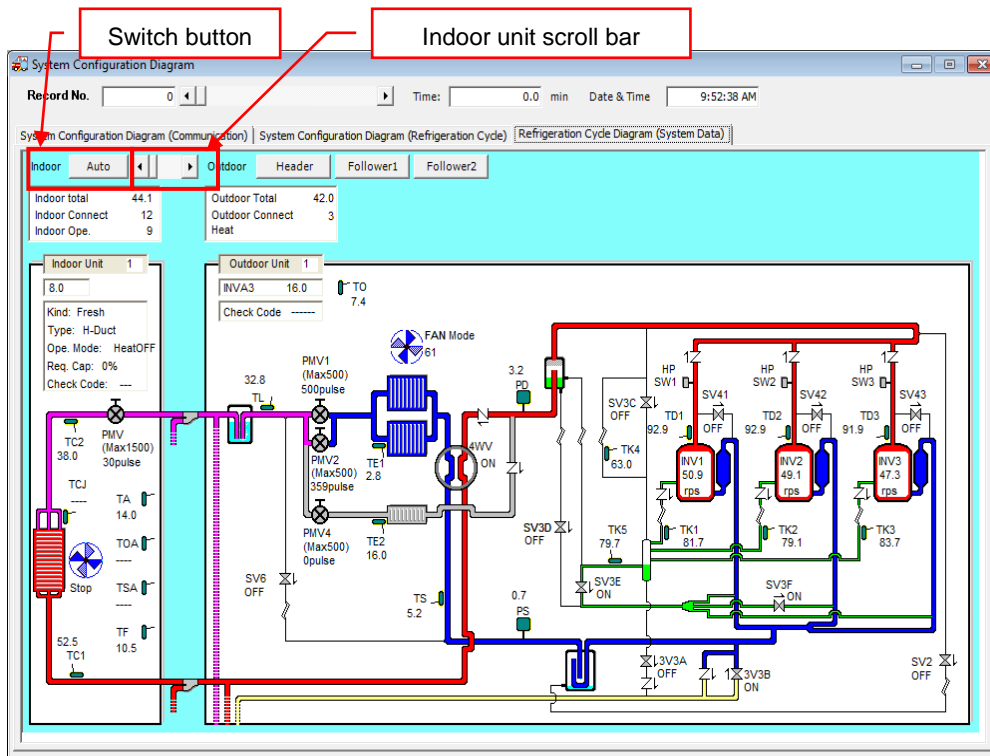
The refrigerant cycle for each indoor/outdoor unit can be checked individually on the refrigerant cycle diagram screen.





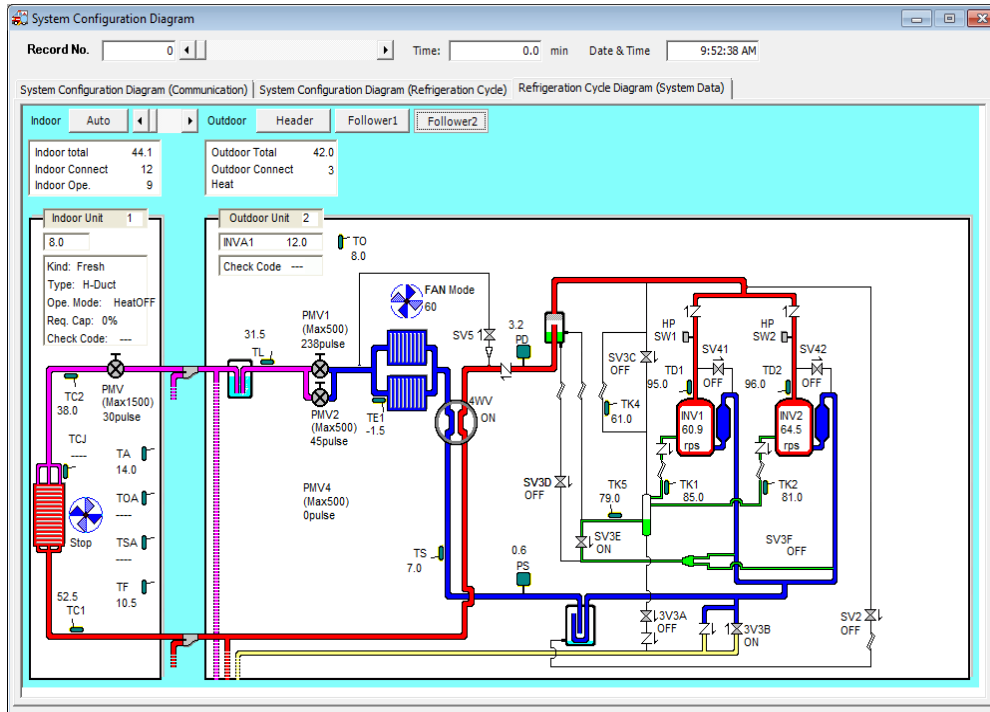
**Figure 5.3.2**

Click the [Switch] button to change the display mode. The display modes are [Automatic] and [Fixed]. In [Automatic] mode the indoor unit changes once a second. In [Fixed] mode the unit being viewed can be changed using the [Indoor unit] scroll bar.



**Figure 5.3.3**

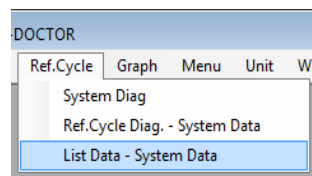
The outdoor unit being displayed can also be changed. Click the [Header], [Follower 1], and [Follower 2] buttons to choose an outdoor unit to be displayed.



**Figure 5.3.4**

#### 5.4. Displaying list data/system data

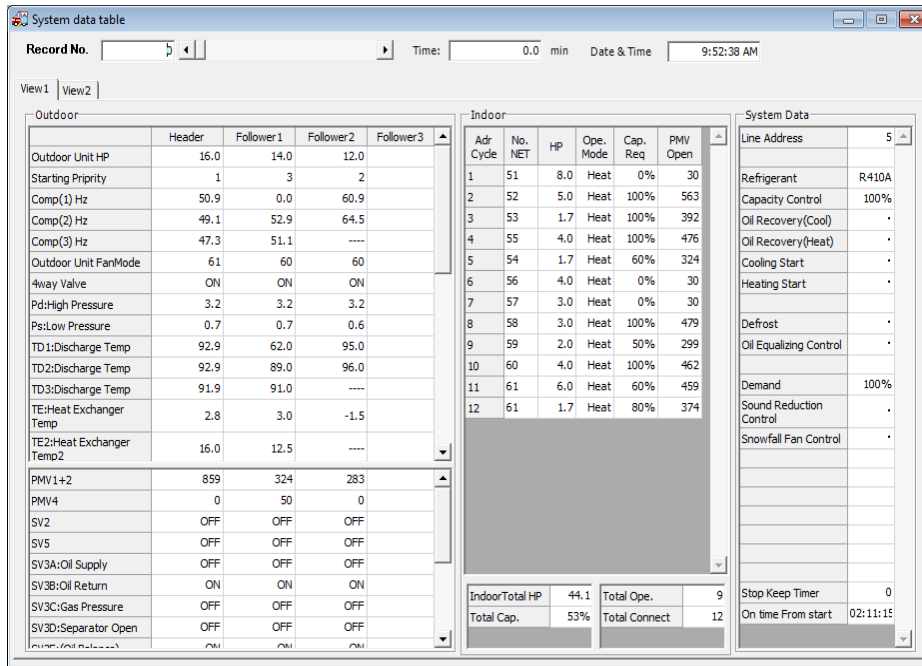
A list of system data can be displayed. To open the system data table window, select [List Data - System Data] from the [Ref. Cycle] menu.



**Figure 5.4.1**

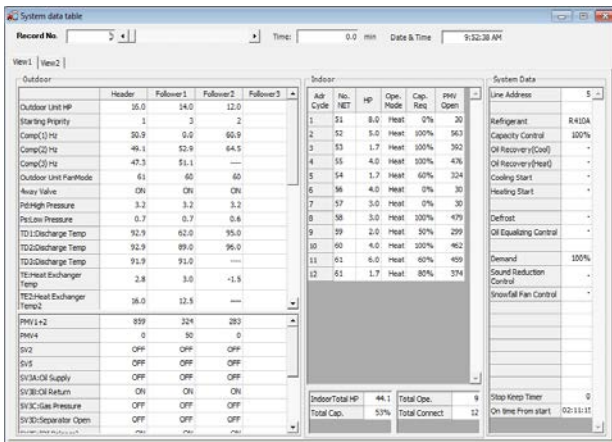
A wait screen is displayed while data is loading. The system data table window is displayed when data has finished loading.

The system data table window can be used to check the status of outdoor/indoor units in a table format.

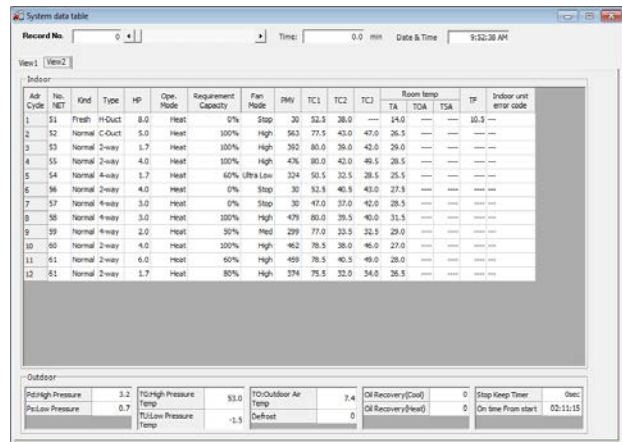


**Figure 5.4.2**

Click [View 1] or [View 2] to switch between the data being displayed.



**Figure 5.4.3**



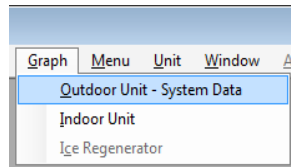
**Figure 5.4.4**

## 6. Displaying graphs

Data can be displayed in graph form. Graphs can be displayed when browsing data files.

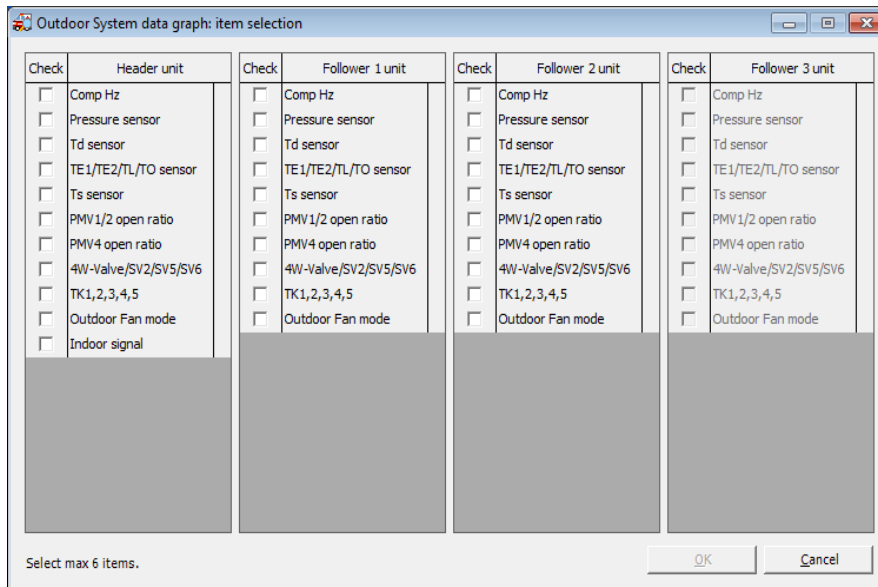
### 6.1. Displaying outdoor unit graphs

Outdoor unit data can be displayed in graph form. To open the outdoor unit graph item selection window, select [Outdoor Unit - System Data] from the [Graph] menu.



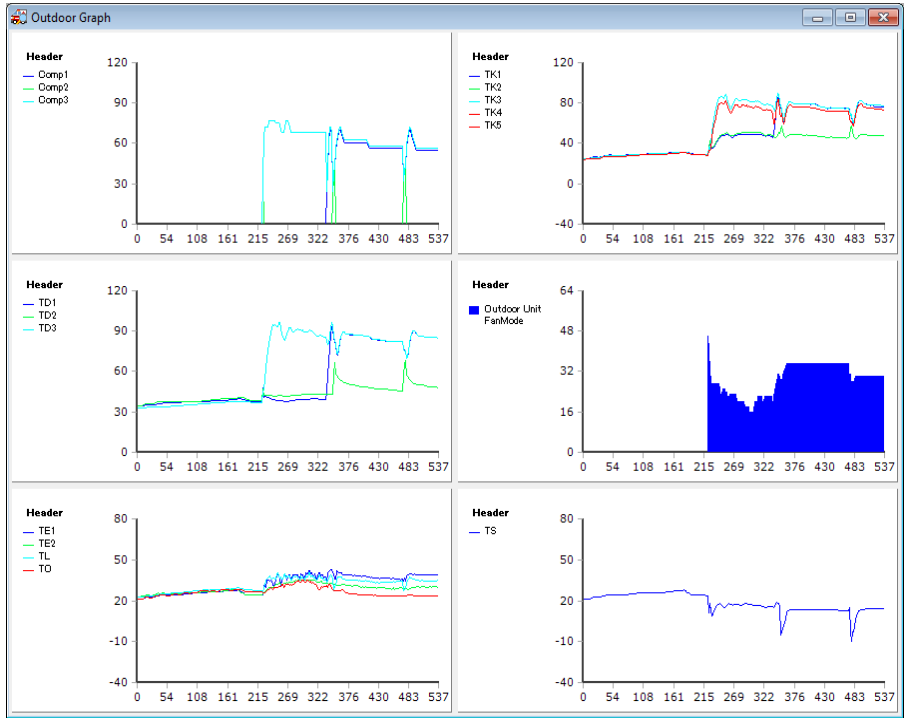
**Figure 6.1.1**

The items to be displayed on the graph can be chosen in the outdoor unit graph item selection window. A maximum of 6 items can be displayed on the graphs.

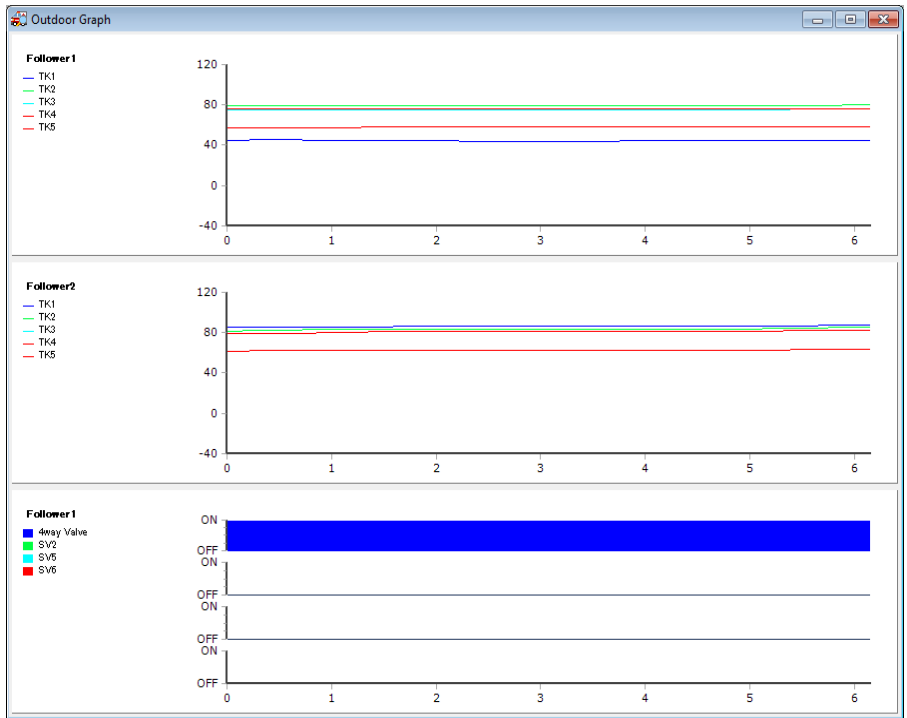


**Figure 6.1.2**

Select the desired item and click the [OK] button to display a graph. When the [OK] button is clicked, a wait screen is displayed while graphs are rendered. When graphs are rendered the graph display window opens.



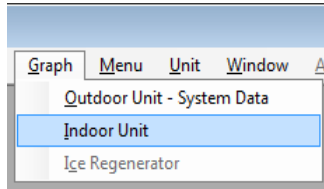
**Figure 6.1.3**



**Figure 6.1.4**

6.2. Displaying indoor unit graphs

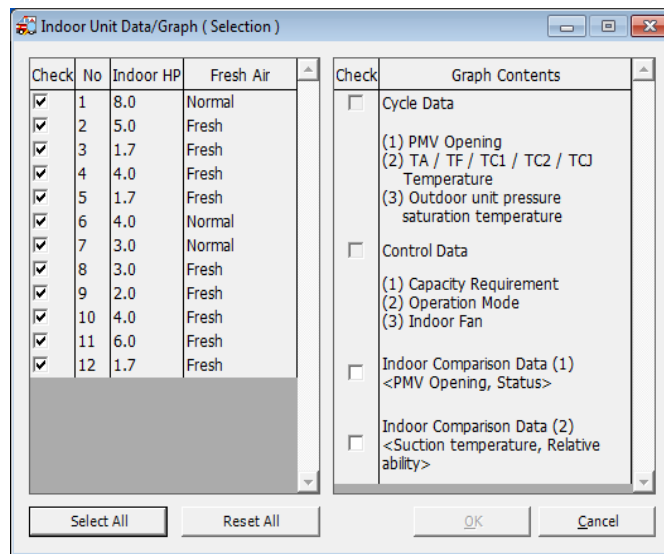
Indoor unit data can be displayed in graph form. To open the indoor unit graph item selection window, select [Indoor Unit] from the [Graph] menu.



**Figure 6.2.1**

The items to be displayed on the graph can be selected in the indoor unit graph item selection window. A maximum of 20 indoor units can be selected. [Cycle Data] and [Control Data] can be selected when 1 unit is chosen. [Indoor Comparison Data] can be selected when 1 or more units are chosen.

[Cycle Data]/[Control Data] and [Indoor Comparison Data] cannot be selected at the same time.



**Figure 6.2.2**

6.2.1. Displaying individual indoor unit graphs

To display graphs for individual indoor units, select 1 indoor unit and cycle data/control data. Then click [OK]. When the [OK] button is clicked, the wait screen is displayed while graphs are rendered. When graphs are rendered the graph display window opens.

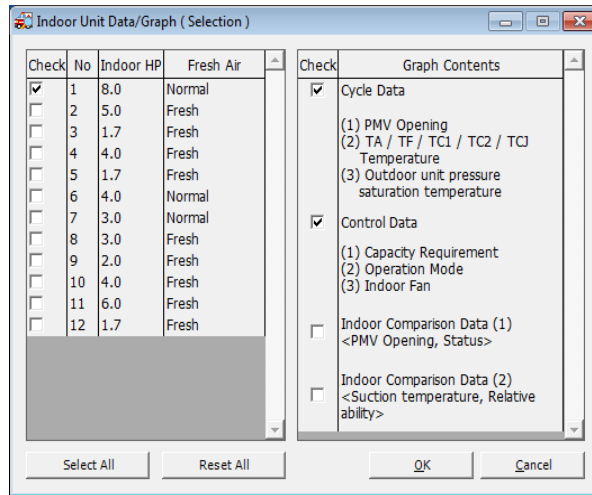


Figure 6.2.3

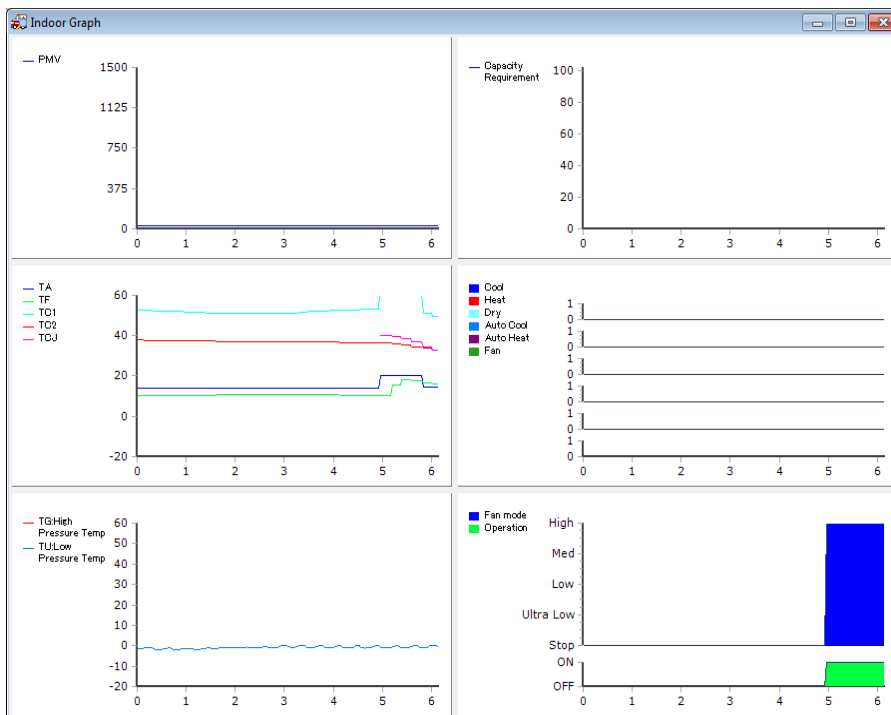


Figure 6.2.4

6.2.2. Displaying [PMV Opening, Status] comparison graphs for indoor units

To display [PMV Opening, Status] comparison graphs for indoor units, select 1 or more indoor units and [PMV Opening, Status]. Then click [OK]. When the [OK] button is clicked, the wait screen is displayed while graphs are rendered. When graphs are rendered the graph display window opens.

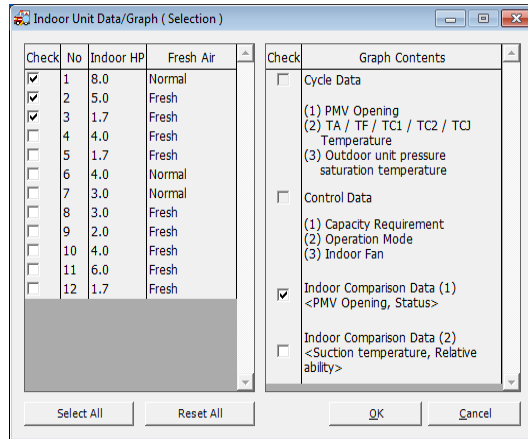


Figure 6.2.5

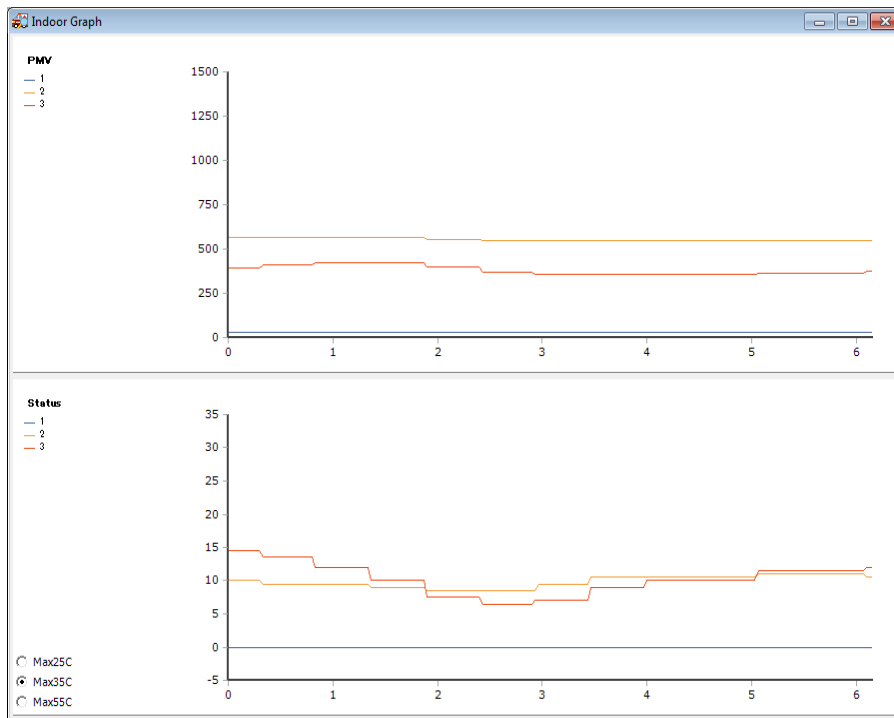
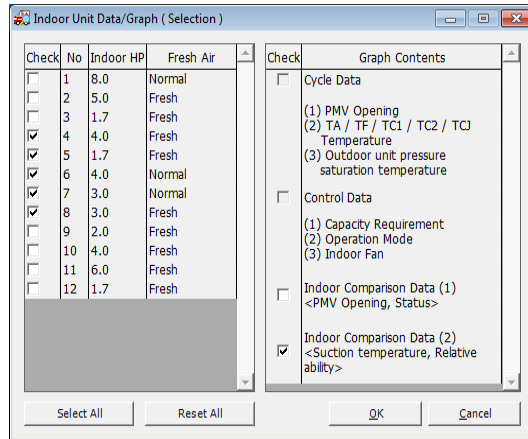


Figure 6.2.6

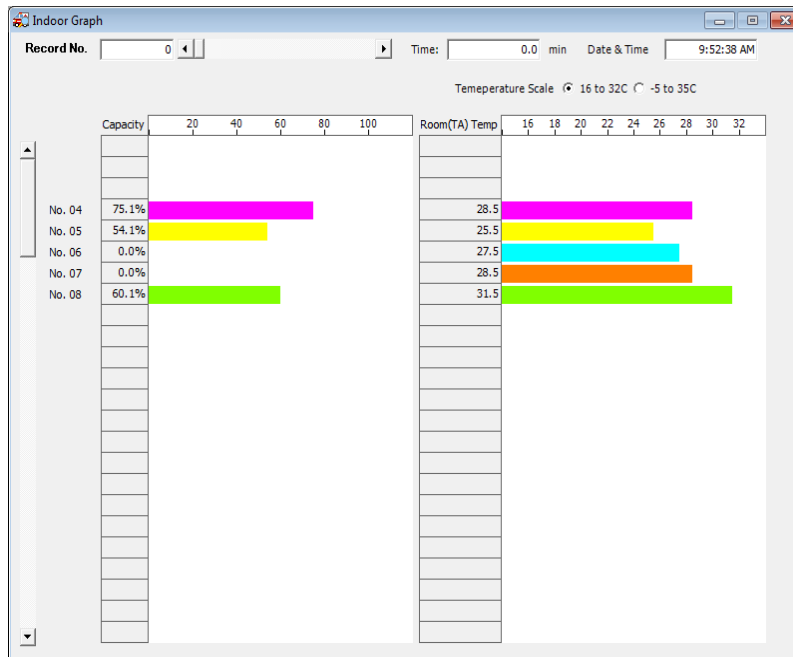


6.2.3. Displaying [Suction Temperature, Relative Ability] comparison graphs for indoor units

To display [Suction Temperature, Relative Ability] comparison graphs for indoor units, select 1 or more indoor units and [Suction Temperature, Relative Ability]. Then click [OK]. When the [OK] button is clicked, the wait screen is displayed while graphs are rendered. When graphs are rendered the graph display window opens.



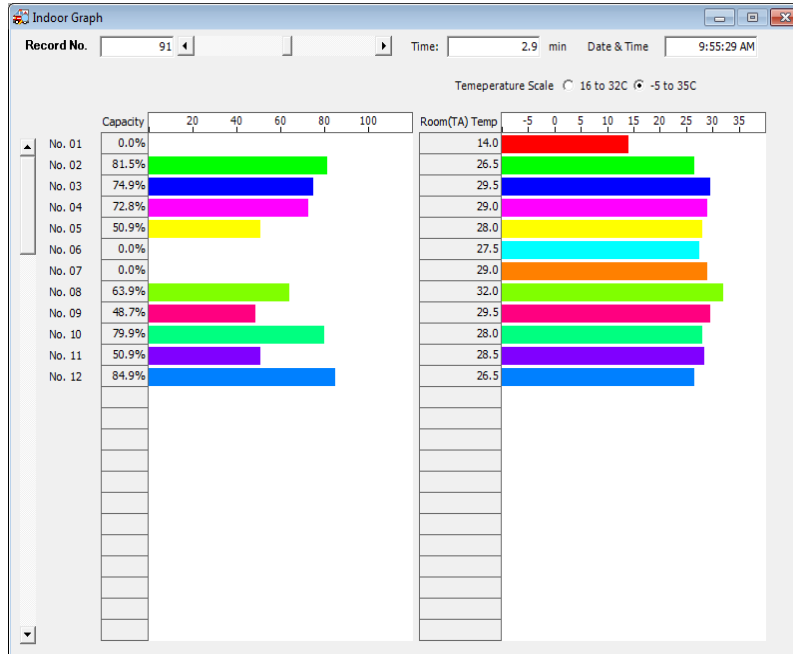
**Figure 6.2.7**



**Figure 6.2.8**

Historical data can be used for [Suction Temperature, Relative Ability] comparison graphs. Refer to [Browsing saved data](#) for more information about using historical data.

Move the scroll bar to change the indoor unit display. The temperature scale can also be changed.

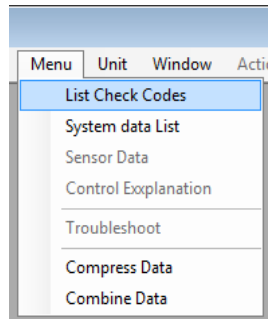


**Figure 6.2.9**

7. Other functions

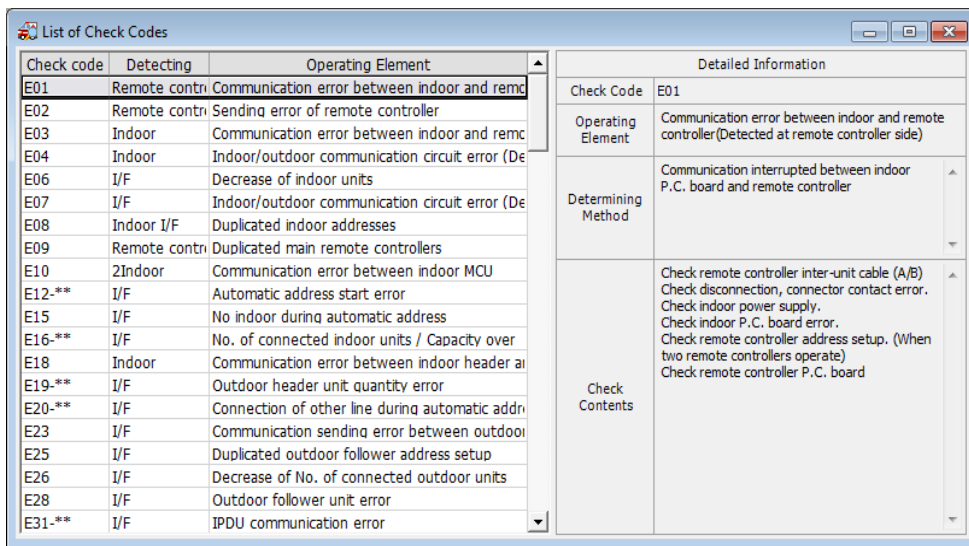
7.1. Checking the list of check codes

Select [List Check Codes] from the [Menu] menu. The list of check codes window opens.



**Figure 7.1.1**

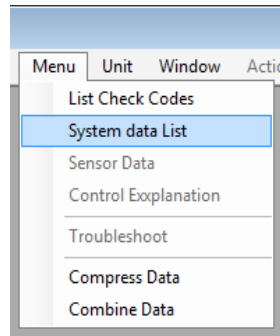
Choose a check code to display detailed information about it.



**Figure 7.1.2**

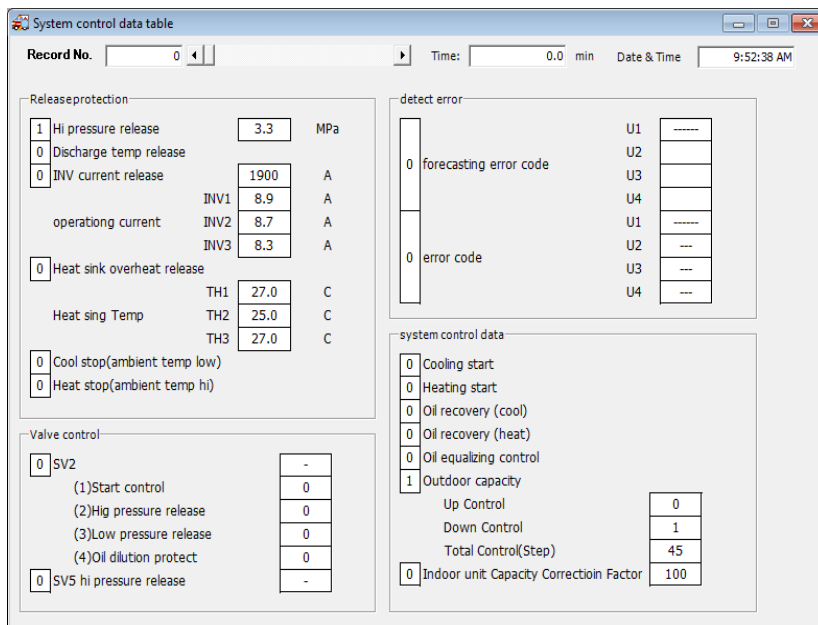
7.2. Displaying a system control data table

Select [System data list] from the [Menu] menu. The system control data table window opens.



**Figure 7.2.1**

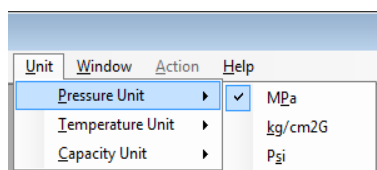
In the system control data table window, system control status information being received or browsed can be checked in table format.



**Figure 7.2.2**

### 7.3. Changing the displayed pressure data unit

The unit used to display pressure data can be changed. To change the unit, select [Pressure unit] from the [Unit] menu, and choose the desired unit.

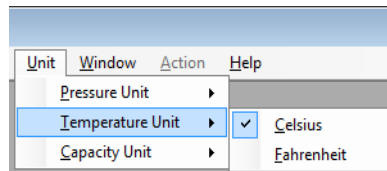


**Figure 7.3.1**

When the unit is changed, the displayed pressure data is displayed using the selected unit.

#### 7.4. Changing the displayed temperature data unit

The unit used to display temperature data can be changed. To change the unit, select [Temperature unit] from the [Unit] menu, and choose the desired unit.

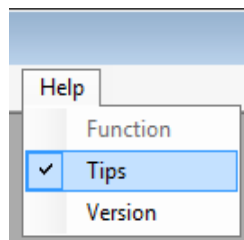


**Figure 7.4.1**

When the unit is changed, the displayed temperature data is displayed using the selected unit.

#### 7.5. Displaying tips

The system tips display can be turned on or off. Select [Tips] from the [Help] menu to turn it on or off.



**Figure 7.5.1**

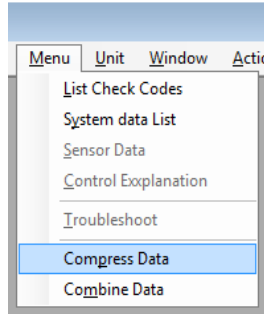
When Tips are turned on, system operation information is displayed in the status bar.



**Figure 7.5.2**

7.6. Compressing data

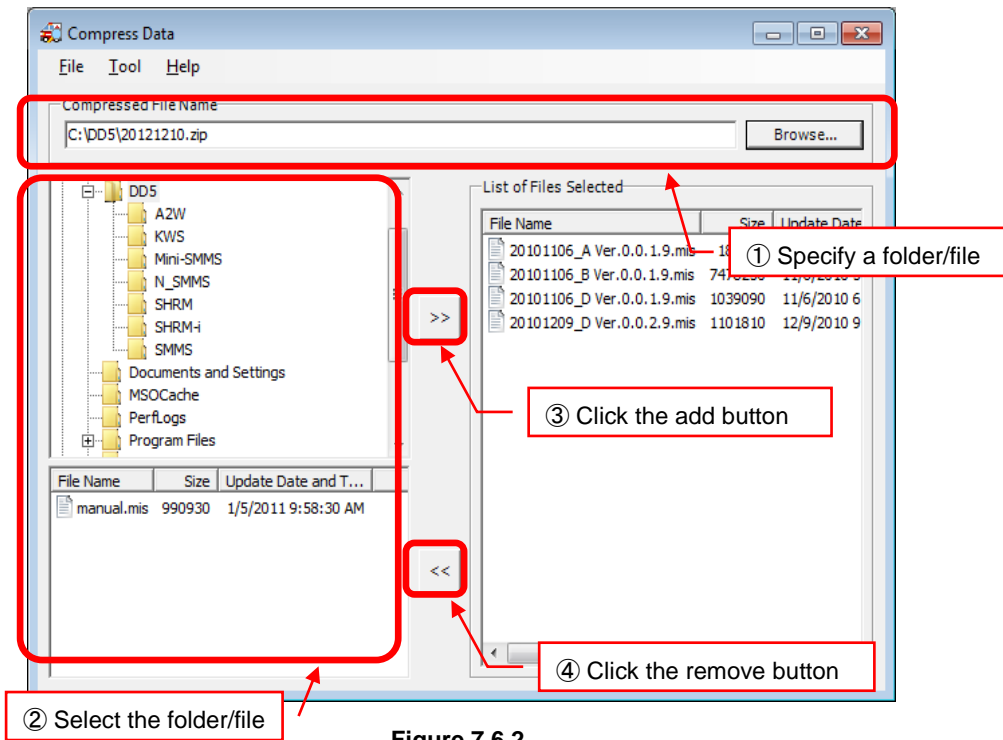
Select [Compress Data] from the [Menu] menu. The compress data window opens.



**Figure 7.6.1**

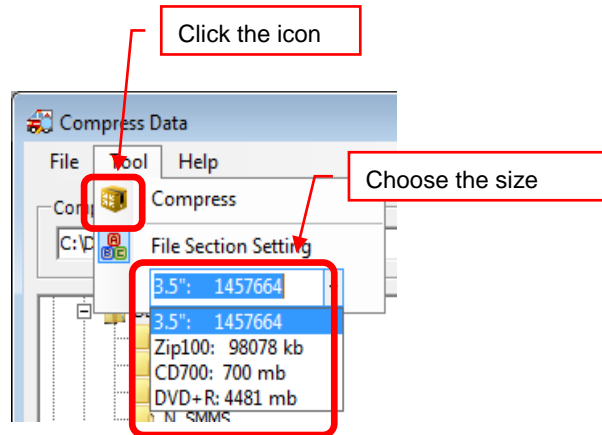
Use the following procedure to compress data:

- ① Specify a folder in which to store the compressed data and a file name.
- ② Select the folder or file which the data to be compressed is saved in.
- ③ Select the files to be compressed and click the [>>] button or drag and drop them to add them.
- ④ To remove selected files, select the file to be removed and click the [<<] button or drag and drop it to remove it.



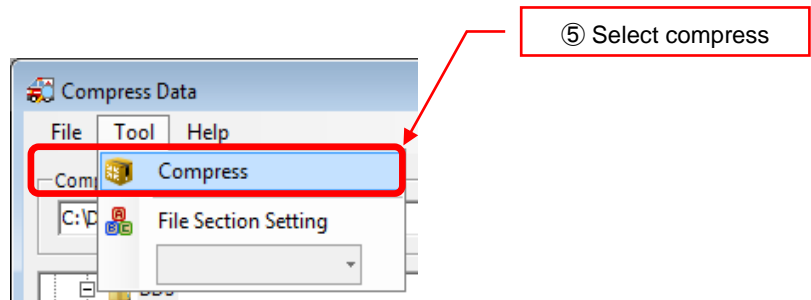
**Figure 7.6.2**

To split and save compressed files, click the file section setting menu and choose the size.



**Figure 7.6.3**

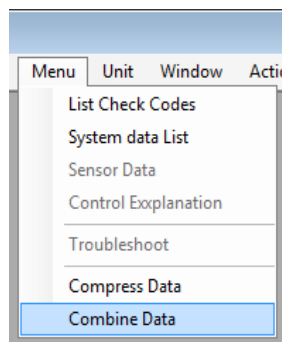
- ⑤ Select [Compress] from the [Tool] menu on the menu bar to perform compression.



**Figure 7.6.4**

### 7.7. Combining data

Select [Combine Data] from the [Menu] menu. The combine data window opens.



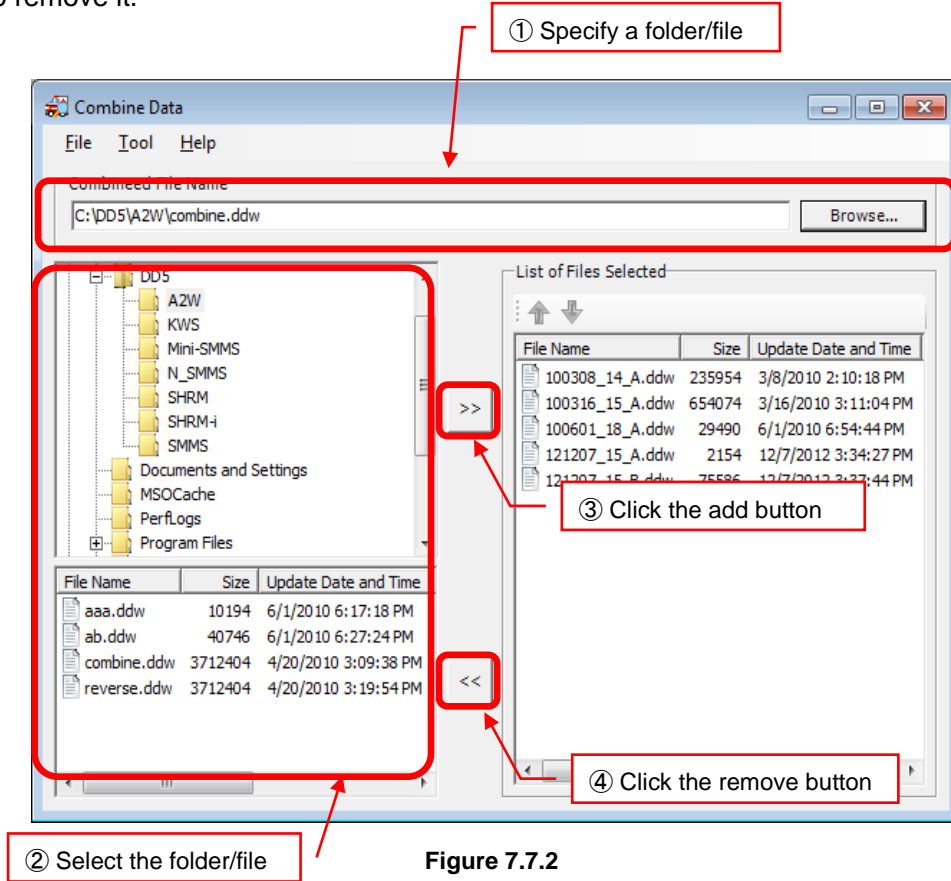
**Figure 7.7.1**

Data split and saved using DynaDoctor can be combined into one consecutive file.

Use the following procedure to combine data:

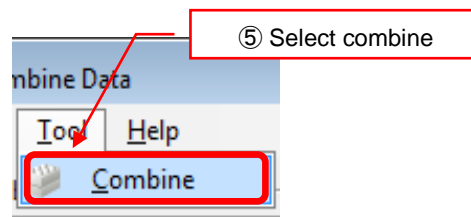
- ① Specify the folder and file name for the combined data file.

- ② Select the folder or file which the data to be combined is saved in.
- ③ Select the files to be combined and click the [>>] button or drag and drop them to add them.
- ④ To remove selected files, select the file to be removed and click the [<<] button or drag and drop it to remove it.





- ⑤ Click the combine button on the tool bar, or select [Combine] from the [Tool] menu on the menu bar to combine the data.



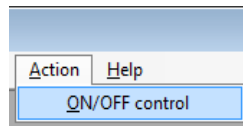
**Figure 7.7.3**

## 8. ON/OFF Control

Operation status and settings can be changed by sending a command to indoor units. ON/OFF control can be used when communicating with the outdoor unit.

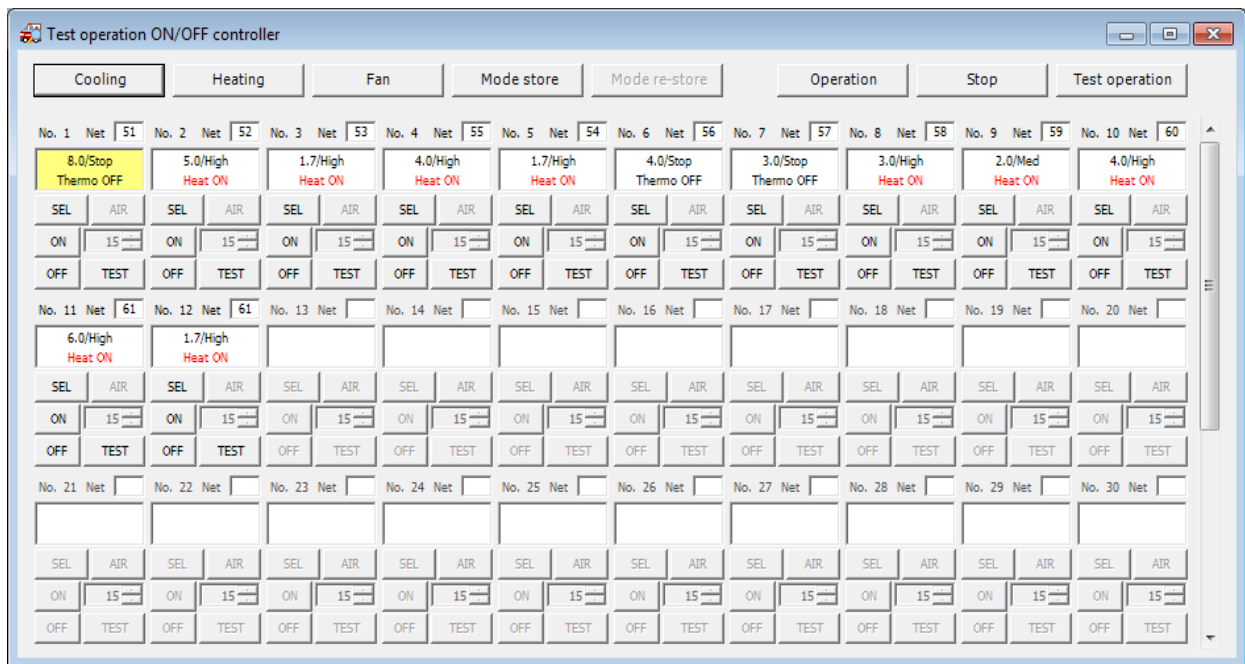
### 8.1. Executing indoor unit test runs

Operation status and settings can be changed by sending a command to indoor units. To open the ON/OFF controller window, select [ON/OFF control] from the [Action] menu.



**Figure 8.1.1**

When the ON/OFF window opens, controls for operating the connected indoor units are displayed. Unconnected indoor unit controls cannot be operated.

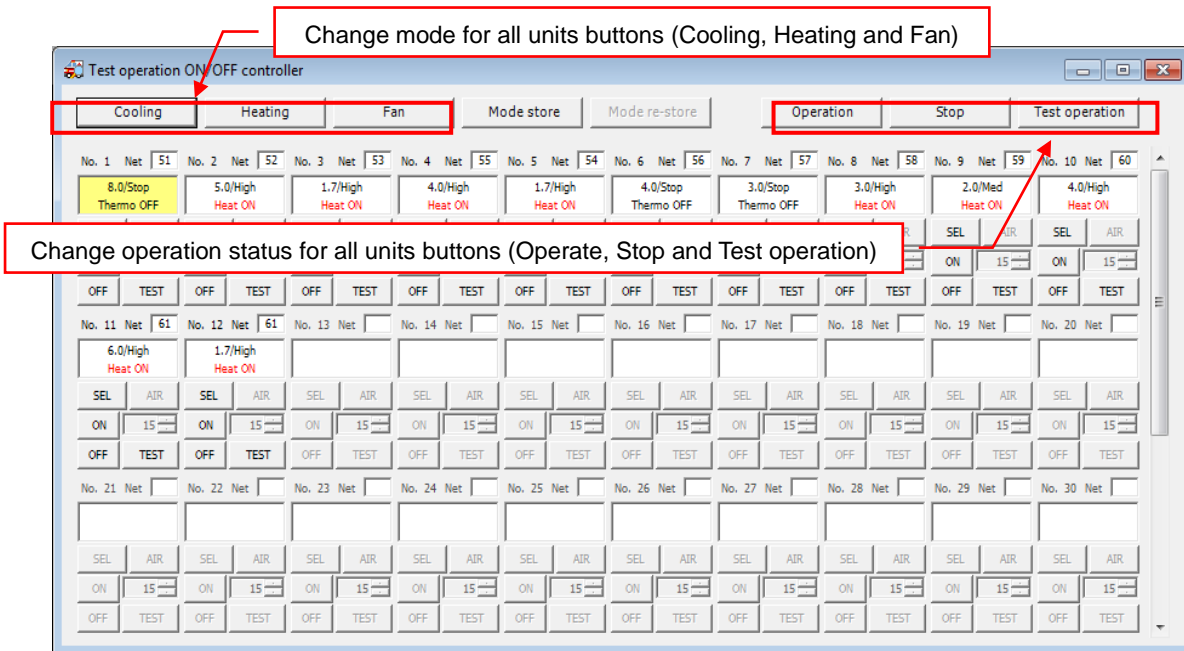


**Figure 8.1.2**

8.1.1. Changing the operation mode for all units

The mode for all indoor units can be changed simultaneously. The mode for all units can be simultaneously changed to 3 different modes - [Cooling], [Heating] and [Fan].

Click the [Cooling], [Heating] and [Fan] buttons to send a mode change command to all indoor units and change the operating mode.



**Figure 8.1.3**

All units can also be simultaneously switched to Operate, Stop and Test Operation. Click the [Operate], [Stop] and [Test Operation] buttons to send a operation status change command to all indoor units and change the operation status.

8.1.1. Changing operation mode for individual units

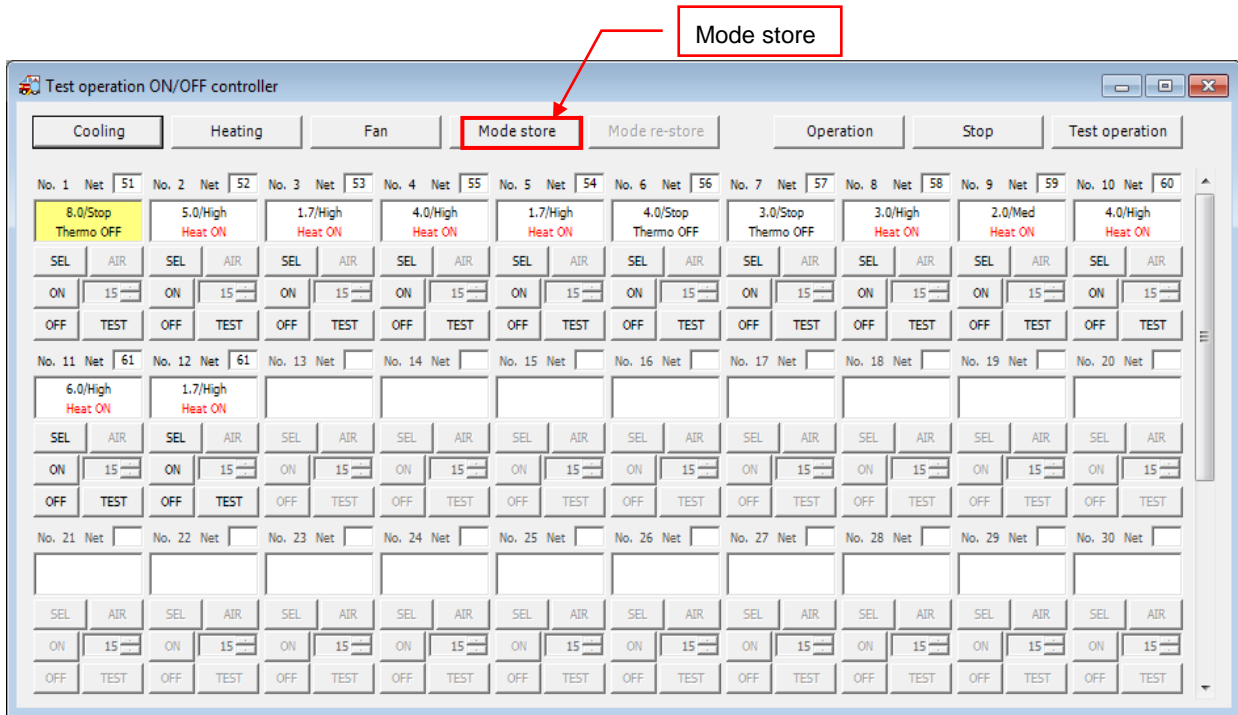
Operation mode for each indoor unit can be changed individually by operating each unit's controls. Click the select operation mode button (initially displayed as SEL) to switch between operation modes in the following order: [Cooling] ⇒ [Heating] ⇒ [Fan]. Click the [ON], [OFF] or [TEST] button to send a command to the relevant unit to change to the chosen operation mode or status.



**Figure 8.1.4**

**8.2. Storing operation modes**

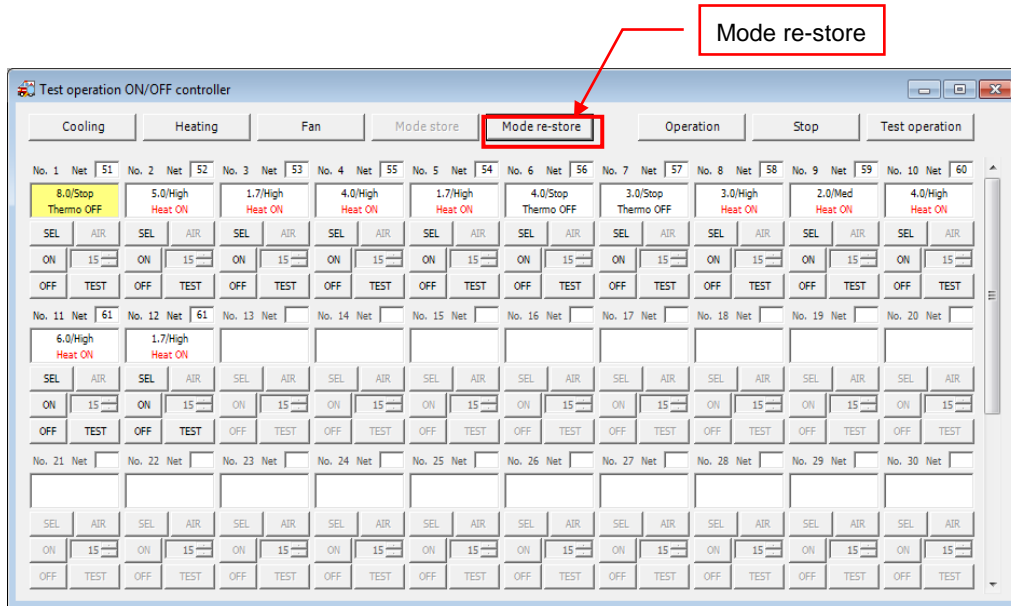
Click the [Mode store] button to save the current indoor unit's operation mode. When the [Mode store] button is clicked, the current indoor unit operation mode is saved. However, saved operation data is erased if communication is halted.



**Figure 8.2.1**

### 8.3. Restoring operation mode

Operation modes saved in [Storing operation modes](#) can be restored. Click the [Mode re-store] button to restore the operation mode. When the [Mode re-store] button is clicked, a command to change to the saved operation mode is sent to each unit.



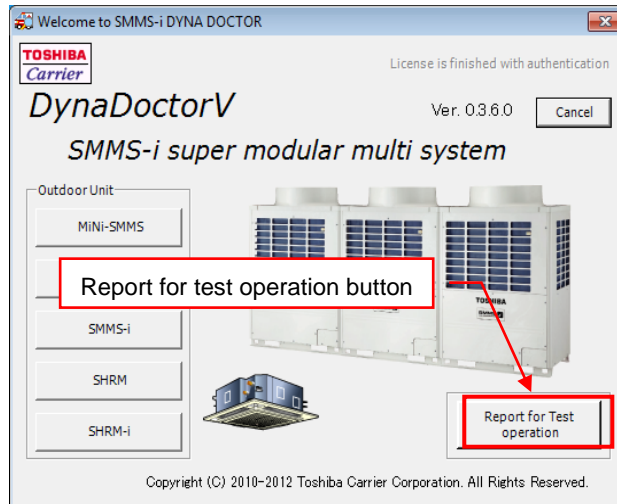
**Figure 8.3.1**

## 9. Creating test run reports

Data saved when communicating with outdoor units can be used to create test run reports. The created data can also be used to print out test run reports.

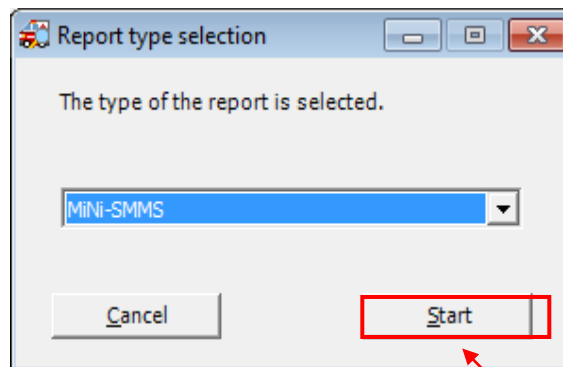
### 9.1. Opening the test operation report window

Click the [Report for Test Operation] button on the main menu screen.



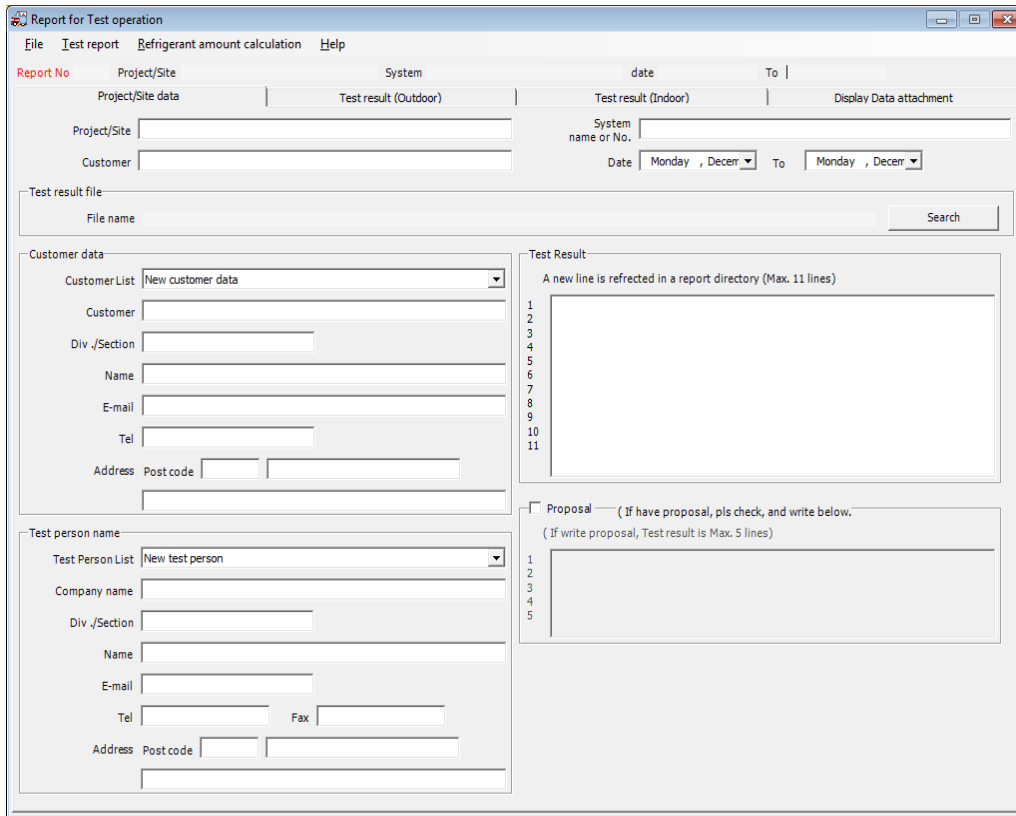
**Figure 9.1.1**

The report type selection window opens. Choose the data for the relevant outdoor unit from the list. Click the [Start] button to open the report for test operation window.



**Figure 9.1.2**

Start button



**Figure 9.1.3**

**9.2. Creating report data**

Enter data into each field on the screen to create report data. The items which can be input are as follows:

**Project/Site data**

Item	Method	Note
Project/Site	Entered by user	Required
System name or No.	Entered by user	
Customer	Entered by user	
Date	Selected by user	
Test result file	Selected by user	Required
Customer	Entered/Selected by user	Required Existing data can be selected from the drop-down list
Div./Section (Customer data)	Entered by user	
Name (Customer data)	Entered by user	
E-mail (Customer data)	Entered by user	
Tel (Customer data)	Entered by user	
Address (Customer data)	Entered by user	
Company name	Entered/Selected by user	Required Existing data can be selected from the drop-down list
Div./Section (Test person name)	Entered by user	
Name (Test person name)	Entered by user	

Item	Method	Note
E-mail (Test person name)	Entered by user	
Tel (Test person name)	Entered by user	
Address (Test person name)	Entered by user	
Test result	Entered by user	
Proposal	Entered by user	

#### Outdoor unit information

Item	Method	Note
Installation location	Entered by user	
Breaker installation location	Entered by user	
No. of outdoor units	Selected by user	Required
Equipment name	Entered by user	
Equipment number	Entered by user	
Piping length	Entered by user	
Additional amount of refrigerant	Entered by user	
Item(s) to be checked	Entered/Selected by user	Required for items which can be selected

#### Indoor unit information

Item	Method	Note
No. of indoor units	Entered by user	Required
Pattern for each type	Selected by user	
Refrigerant name	Selected by user	
Date	Selected by user	
Inspector	Entered by user	
Breaker capacity	Selected by user	
Measured value or judgement	Entered by user	
Installation location	Entered by user	
Model	Entered by user	
Equipment number	Entered by user	
Item(s) to be checked	Entered/Selected by user	

#### Data attachments

Item	Method	Note
Refrigerant cycle operation status	Selected by user	Required
System data list	Selected by user	
Indoor unit operation status	Selected by user	
Outdoor unit operation graphs	Selected by user	
System configuration diagram (communication)	Selected by user	
System configuration diagram (refrigerant cycle)	Selected by user	



### 9.2.1. Specifying test result data

To specify test result data, click the [Search] button. A select file dialogue is displayed. Select the file to be used to create the report.

When a file is selected, the file path appears in the test result file text box.

**Figure 9.2.1**

Search button

### 9.2.2. Creating customer/test person data

To create customer/test person data, choose [New customer data] from the drop down menu and enter the data. To edit existing customer/test person data, choose the data to be edited from the drop down menu and enter the data.

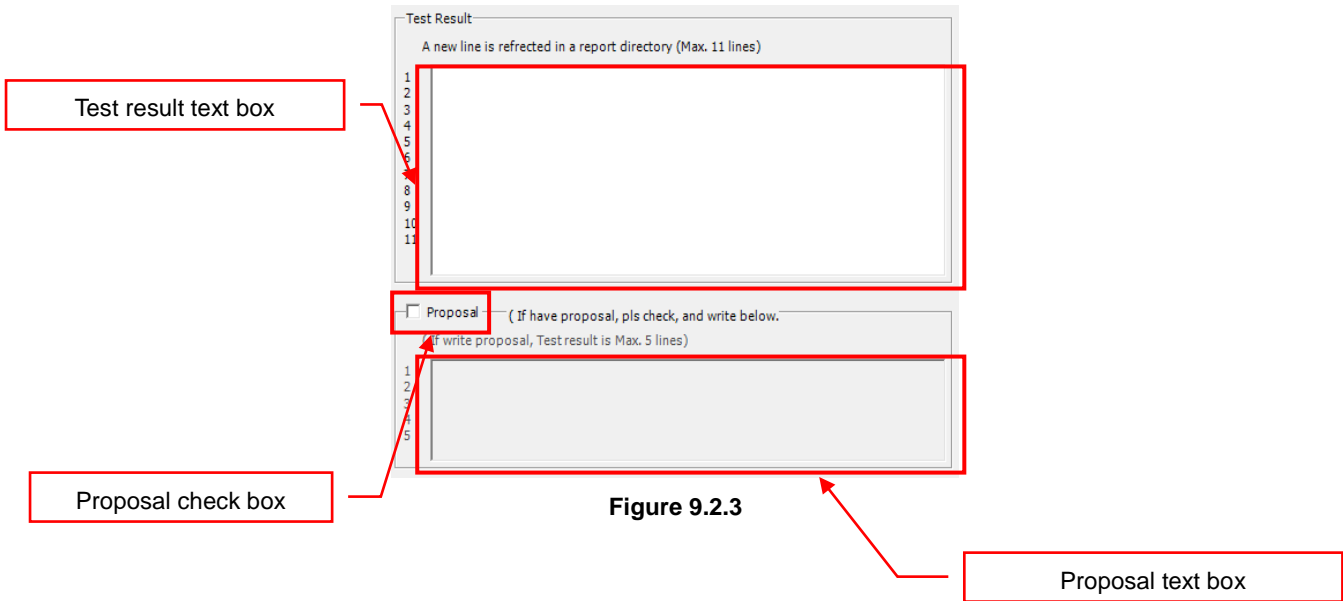
When report data is registered, the new customer/test person data is added or updated.

**Figure 9.2.2**

### 9.2.3. Entering test results/proposals

Enter test results data into the [Test Result] text box. Check the [Proposal] box to enter a proposal. Data can then be entered into the [Proposal] text box.

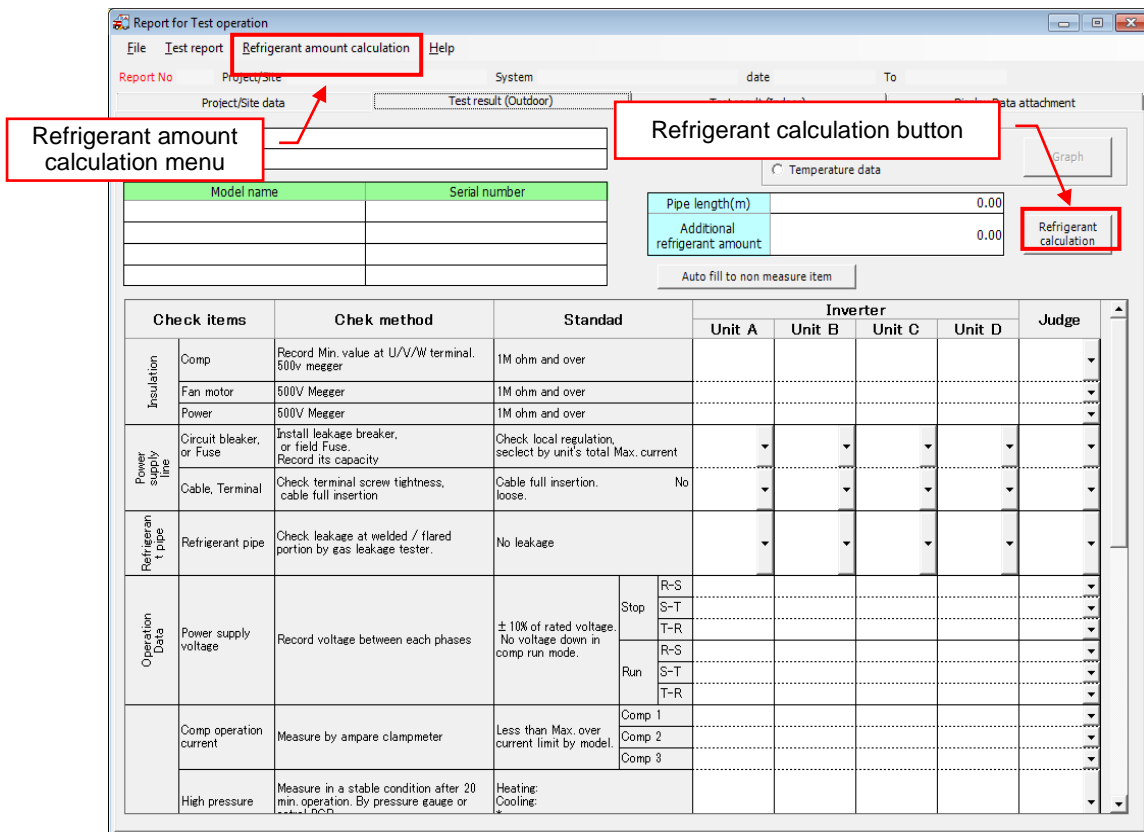
If a proposal is entered, only 5 lines of test result data can be entered.



**Figure 9.2.3**

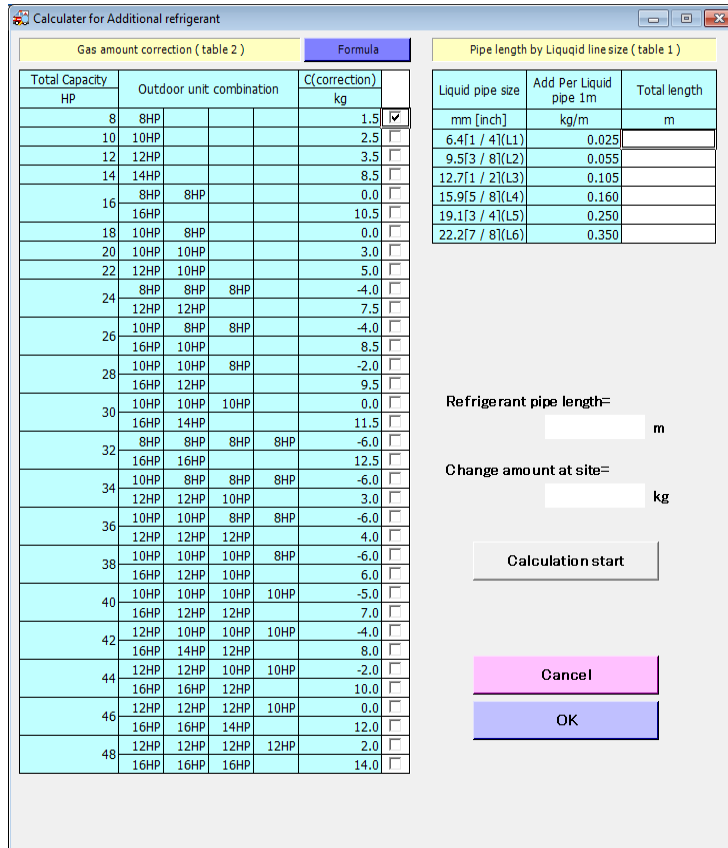
**9.2.4. Entering pipe lengths/additional amount of refrigerant**

To enter the amount of added refrigerant and pipe lengths for the whole system, select the [Refrigeration amount calculation] menu or click the [Refrigerant calculation] button. Click the [Refrigerant calculation] button to open an additional refrigerant amount window.



**Figure 9.2.4**

In the calculator for additional refrigerant window, the outdoor unit model can be chosen, and pipe lengths can be entered. The entered results are used to calculate the refrigerant pipe length and the amount of additional refrigerant.



**Figure 9.2.5**

To calculate the refrigerant pipe length and the amount of additional refrigerant:

First, check the check box for the total capacity (hp) of the outdoor unit which executed test operation.

Next, enter the lengths of the connected pipes for each pipe diameter.

After entering the data, click the [Calculation start] button to calculate the refrigerant pipe length and the amount of additional refrigerant. Click the [OK] button to save the calculated results.

**Figure 9.2.6**

Click the [OK] button to close the calculator for additional refrigerant window, and automatically enter the calculated results for the outdoor unit [Pipe length] and [Additional refrigerant amount].

Pipe length(m)	30.00	Refrigerant calculation
Additional refrigerant amount	10.25	

**Figure 9.2.7**

**9.2.5. Checking the refrigerant amount calculation formula**

Click the [Formula] button to check the formula for additional refrigerant amount calculation. The formula for additional refrigerant amount window opens when the [Formula] button is clicked.

The formula for calculating the additional refrigerant amount can be checked in the formula for additional refrigerant amount window. Click the [Back] button to return to the calculator for additional refrigerant window.

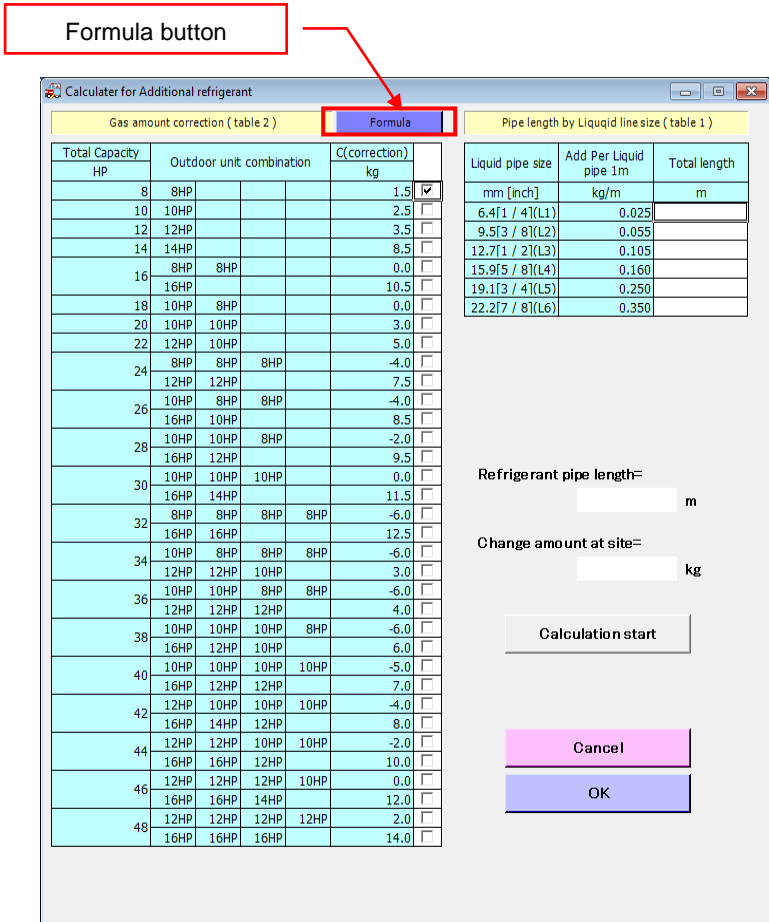


Figure 9.2.8

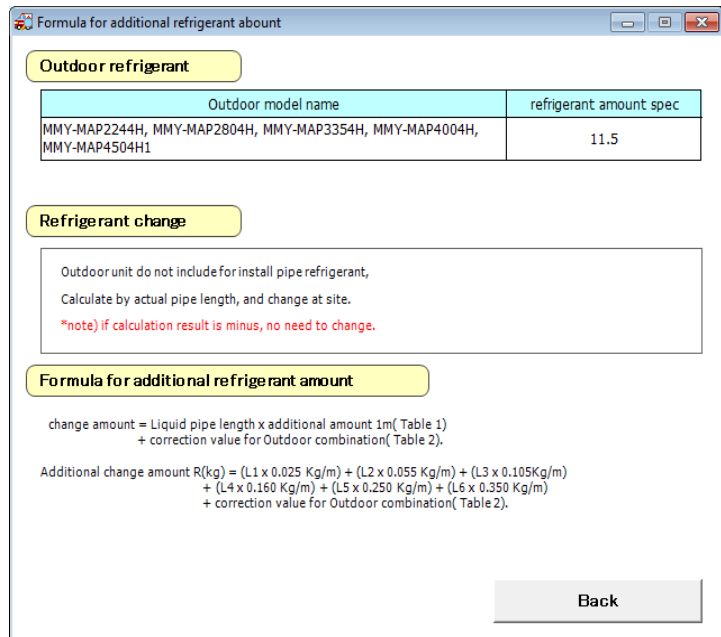


Figure 9.2.9

9.2.6. Automatically filling in test results

The test results for outdoor/indoor units can be filled in automatically. To automatically fill in results:

Outdoor units - click the [Auto fill to non measure item] button in the [Outdoor unit] tab.

Indoor units - click the [Auto fill to non measure item] button on the [Indoor unit] tab.

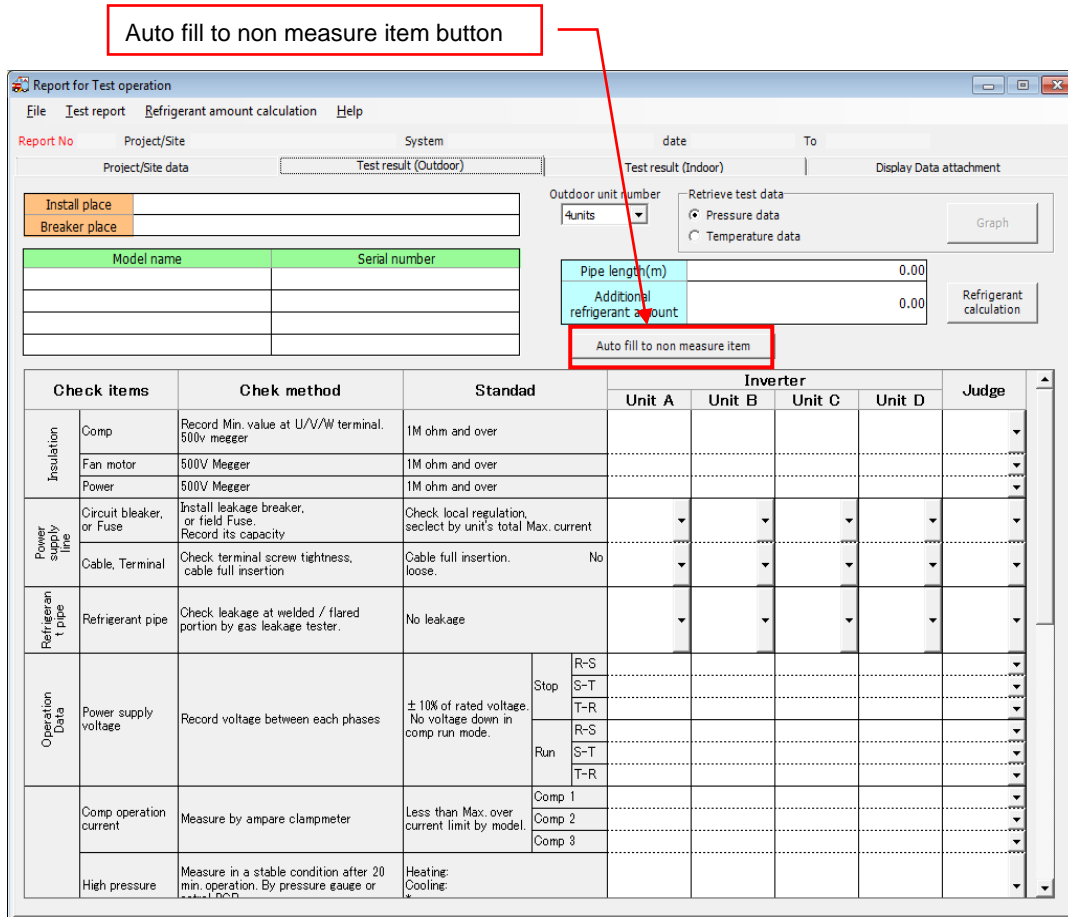
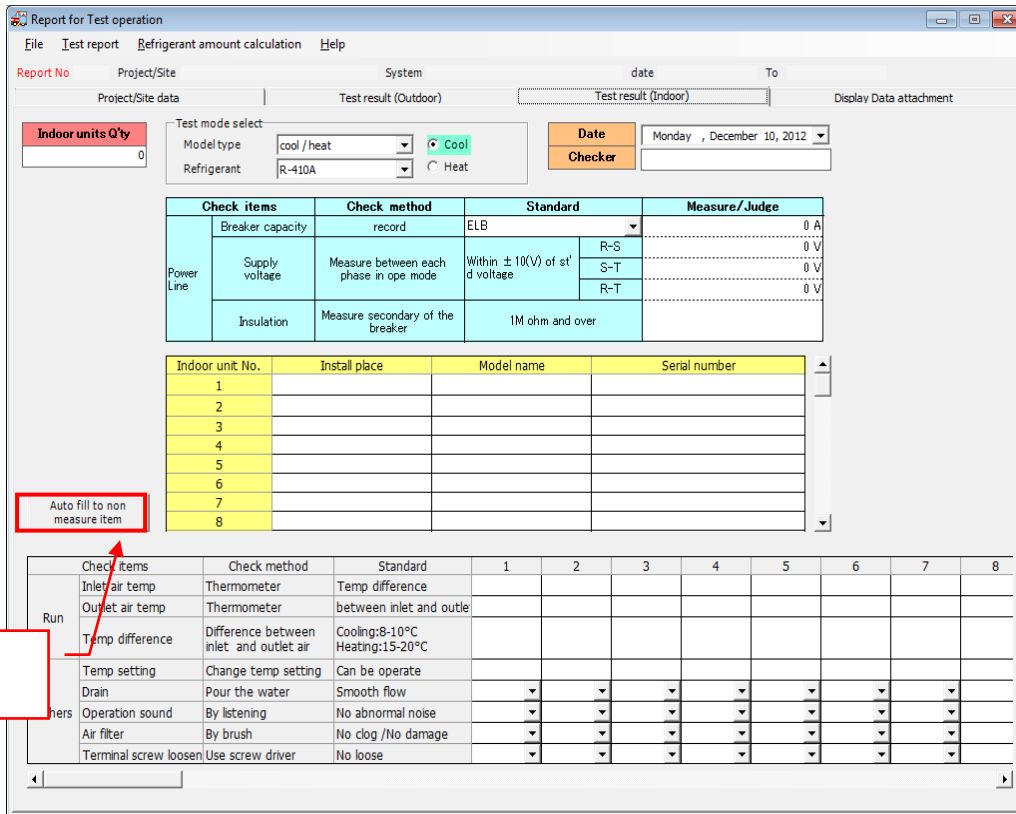
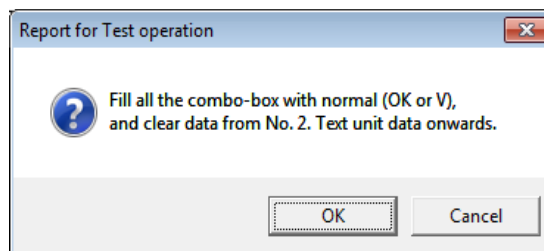


Figure 9.2.10



**Figure 9.2.11**

If the number of outdoor/indoor units is below the maximum, a confirmation message appears. Click the [OK] button to automatically fill in the test results.



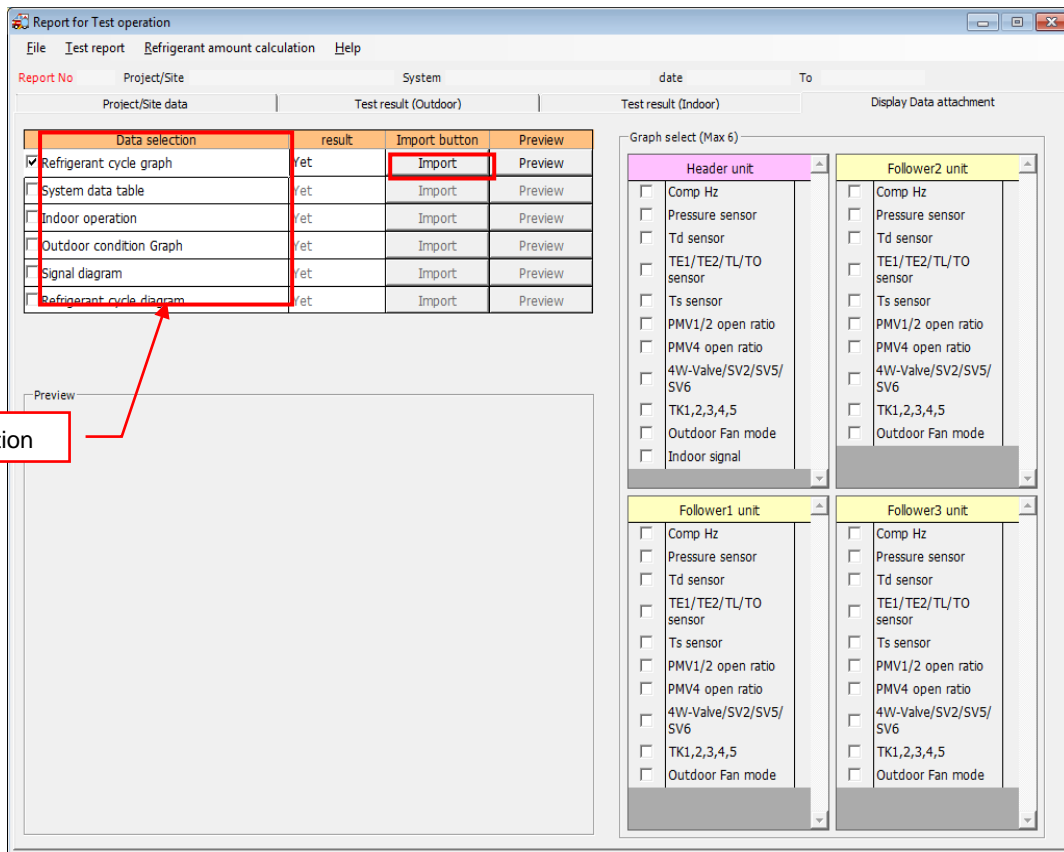
**Figure 9.2.12**

### 9.2.7. Importing screens

System status can be imported as a picture using the test result file data. Screens can be imported when a test result file is saved.

Select the screen to be imported from the [Data selection] list displayed on screen. Then click the [Import] button when it can be clicked.

**Import**



**Figure 9.2.13**

The wait screen is displayed while the screen is rendering. When it has been rendered, the selected screen is displayed.

The [Record No.] and scroll bar for browsing data appear on the import screen. Display the data to be imported, and select the [Retrieve] menu to import the screen data. Click the [Preview] button to check the imported screen data.



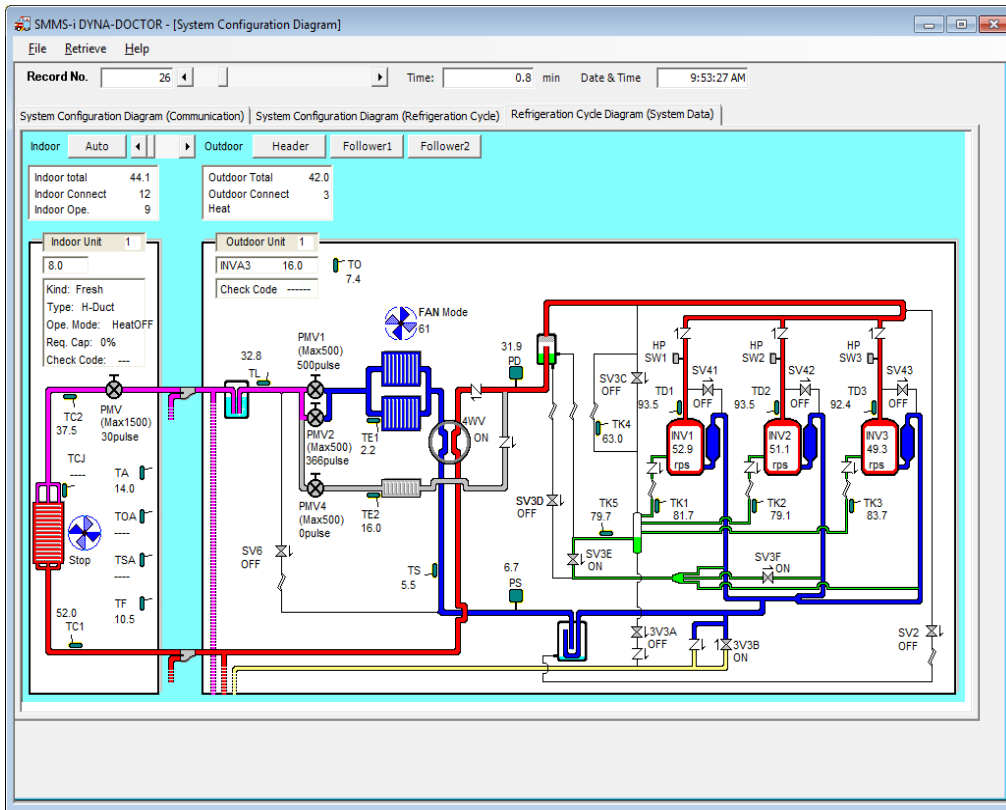


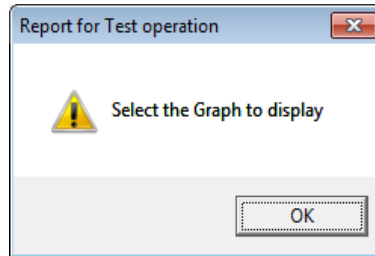
Figure 9.2.14

Preview

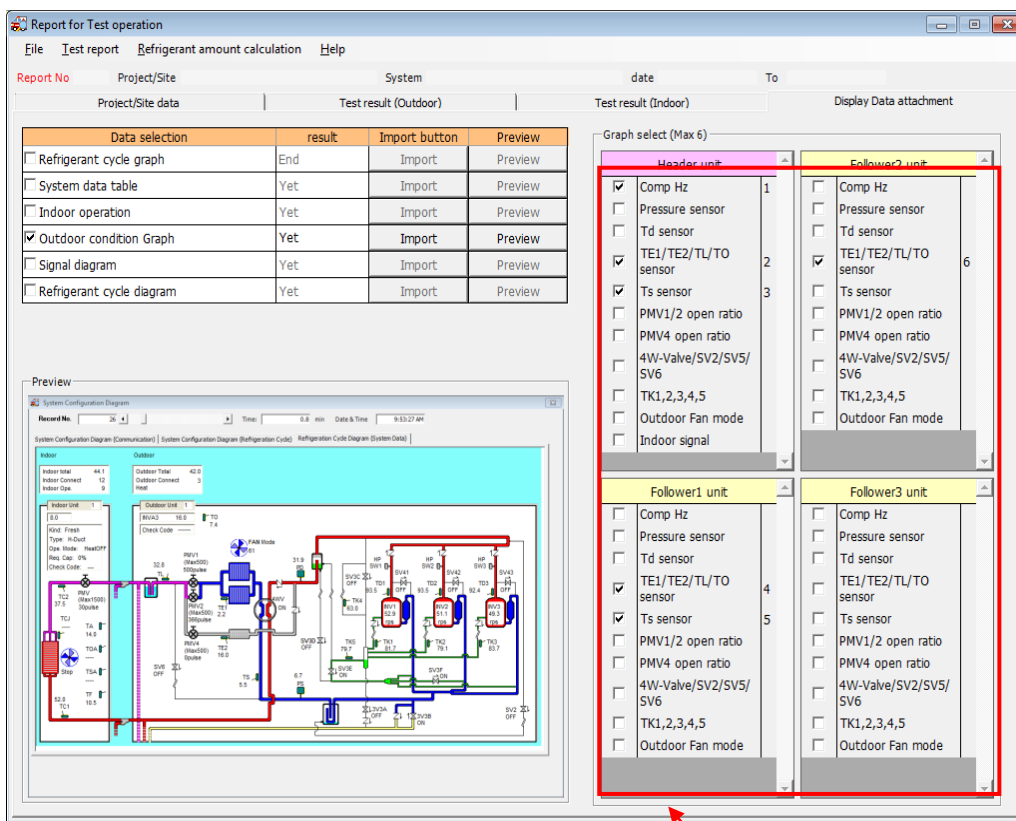
Data selection	result	Import button	Preview
<input checked="" type="checkbox"/> Refrigerant cycle graph	End	Import	Preview
<input type="checkbox"/> System data table	Yet	Import	Preview
<input type="checkbox"/> Indoor operation	Yet	Import	Preview
<input type="checkbox"/> Outdoor condition Graph	Yet	Import	Preview
<input type="checkbox"/> Signal diagram	Yet	Import	Preview
<input type="checkbox"/> Refrigerant cycle diagram	Yet	Import	Preview

Figure 9.2.15

To import a screen from the [Outdoor unit operation graph list], graph items must be selected. If an attempt to import the [Outdoor unit operation graph list] is made without any graph items selected, an error message is displayed.



**Figure 9.2.16**

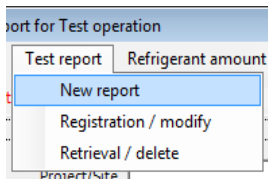


**Figure 9.2.17**

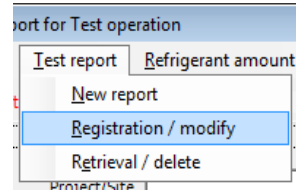
Graph items

**9.2.8. Registering report data**

Select [Registration/modify] from the [Test report] menu to register entered report data. To register new data, select [New report] from the [Test report] menu and allocate a [Report No.]. Then select [Registration/modify].

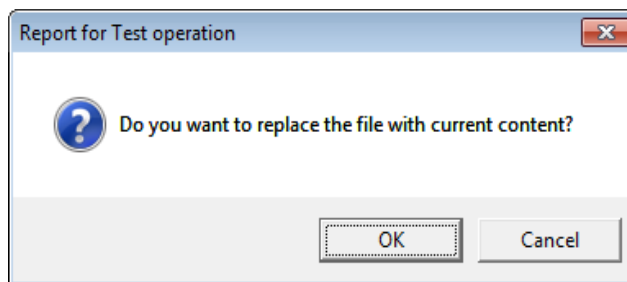


**Figure 9.2.18**

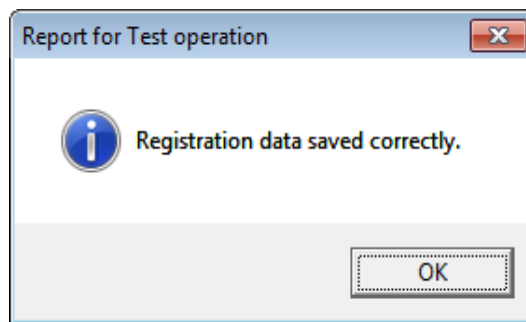


**Figure 9.2.19**

When [Registration/modify] is clicked a register/modify report data message is displayed. Click [OK] to start registering the report data to the database file. If the report data is registered correctly, a registration complete message is displayed.

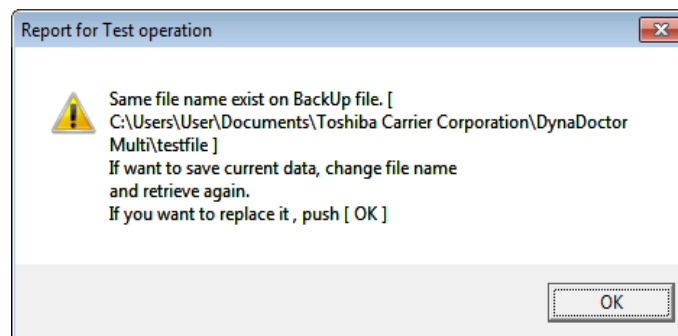


**Figure 9.2.20**



**Figure 9.2.21**

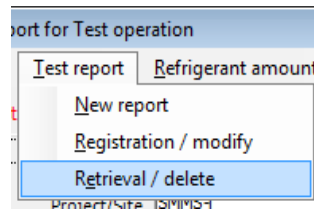
If a test data file which has already been registered is registered again, a test results data confirmation message is displayed.



**Figure 9.2.22**

9.3. Searching for report data

Registered report data can be searched. Select [Retrieval/delete] from the [Test report] menu to open the test report retrieve window.

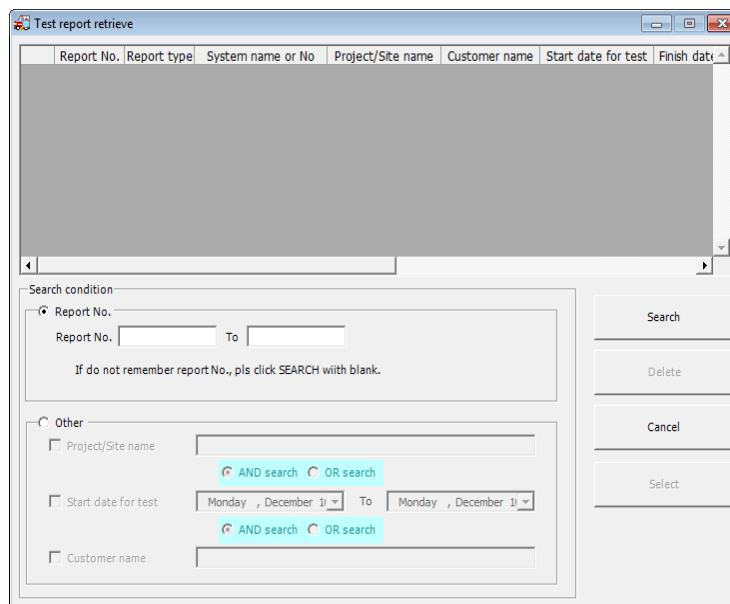


**Figure 9.3.1**

In the test report retrieve window, search conditions can be set and relevant report data can be retrieved. The following conditions can be set for searches:

Item	Method	Note
Report No.	Entered by user	
Project/site name	Entered by user	
Start date for test	Selected by user	
Customer name	Entered by user	

If no search conditions are set, all of the registered report data will be shown in the search results.



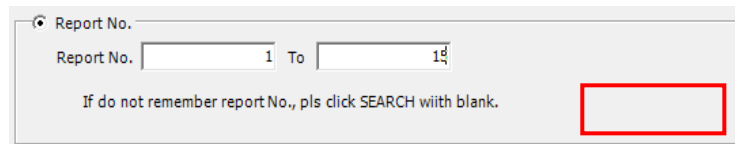
**Figure 9.3.2**



### 9.3.1. Searching by Report No.

Click the radio button next to [Report No.] to select a report no. to search for. Report numbers can be entered when the [Report No.] radio button is selected.

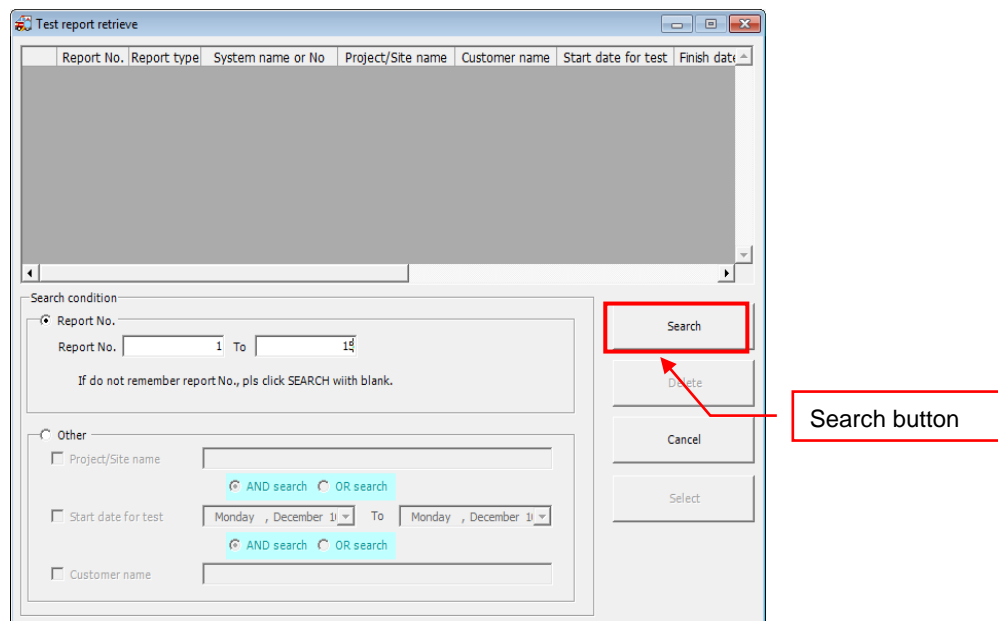
To specify the report numbers to search for, enter numbers in the text boxes next to [Report No.] and [To]. If the starting report no. or finishing report no. is unclear, leave the box blank.



The screenshot shows a dialog box titled "Report No." with a radio button selected. Below the radio button are two text input fields: "Report No." containing the number "1" and "To" containing "1d". Below these fields is the text "If do not remember reportNo., pls click SEARCH with blank." To the right of this text is a red rectangular box, which is the "Search" button.

**Figure 9.3.3**

Click the [Search] button to search for report data with the specified report no.



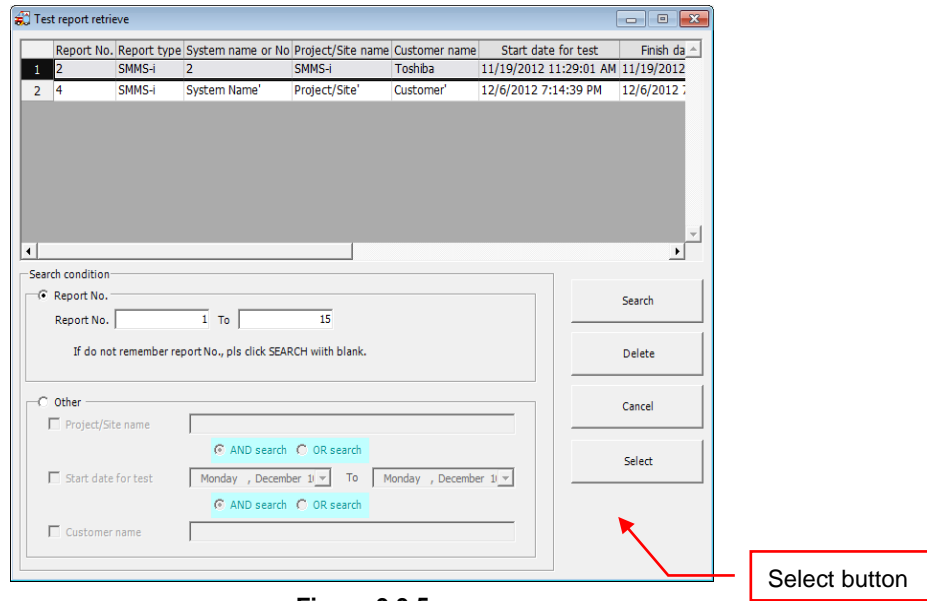
The screenshot shows the "Test report retrieve" dialog box. It has a table header with columns: Report No., Report type, System name or No, Project/Site name, Customer name, Start date for test, and Finish date. Below the table is a "Search condition" section with a radio button selected for "Report No.". This section contains the same "Report No." and "To" fields as in Figure 9.3.3. Below this is an "Other" section with checkboxes for "Project/Site name", "Start date for test", and "Customer name". There are also "AND search" and "OR search" options. To the right of the search condition section are four buttons: "Search", "Delete", "Cancel", and "Select". The "Search" button is highlighted with a red box, and a red arrow points to it from a label "Search button" also enclosed in a red box.

**Figure 9.3.4**

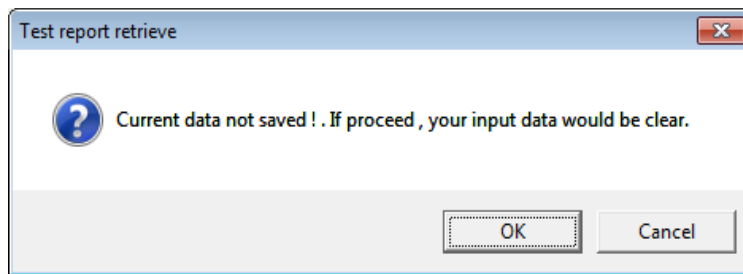
If report data is found which fits the set conditions, it is displayed on screen. To display the contents of the report data, select the data and click the [Select] button.

A confirmation message is displayed before the data is displayed. If the currently entered data does not need to be registered, click the [OK] button.

The selected report data is displayed when the [OK] button is clicked.



**Figure 9.3.5**



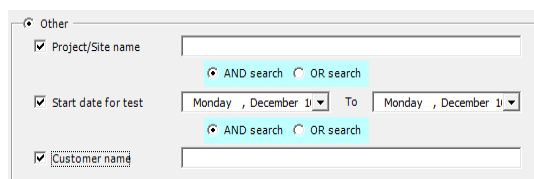
**Figure 9.3.6**

9.3.2. Searching by project/site name, test start date and customer name

To select and search for project/site name, the test start date or customer name, click the radio button next to [Other]. When the [Other] radio button is selected, project/site name, the test start date and customer name can be entered.

To search for a project/site name, check the [Project/Site name] check box. When [Project/Site name] is checked, data can then be entered into [Project/Site name].

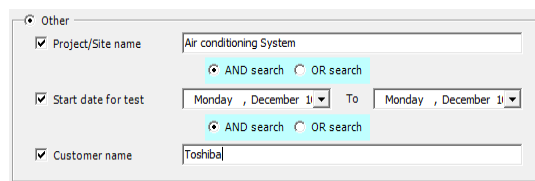
Check [Start date for test] to set a test start date to search for. Check [Customer name] to set a customer name to search for.



**Figure 9.3.7**

When several search items have been entered, AND search or OR search can be selected. If the AND search is checked, report data which matches both conditions will be searched for. If the OR search is checked, report data which matches one or more of the conditions will be searched for.

For example, if information is entered as below, report data in which the project/site name is "Air Conditioning System" and the start date is "February 2nd 2011", or the customer name is "Toshiba", will be searched for.



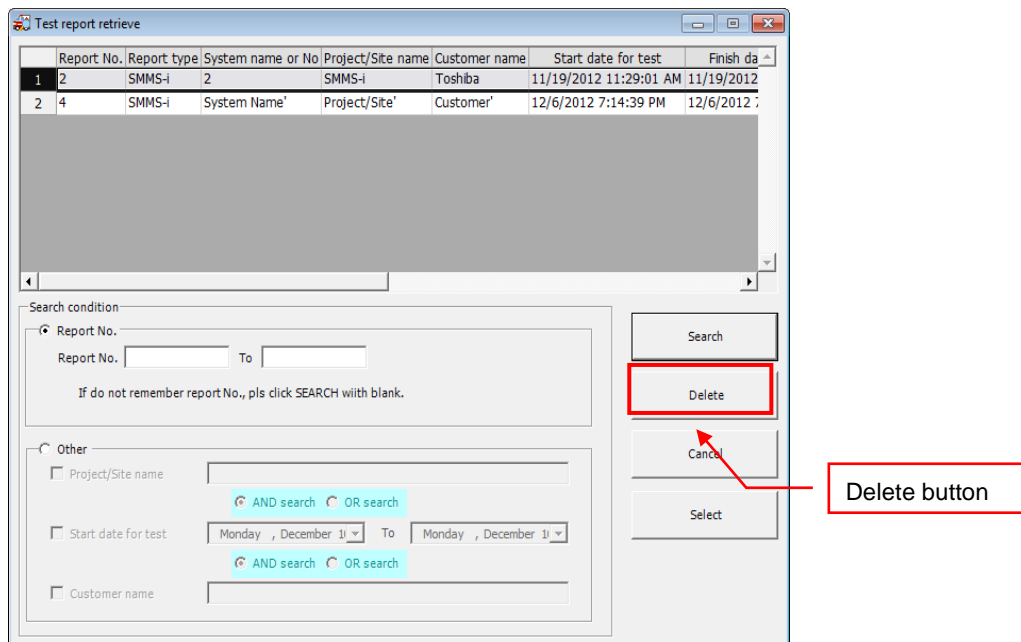
The screenshot shows a search criteria form with the following fields and options:

- Other
- Project/Site name: Air conditioning System
- AND search  OR search
- Start date for test: Monday, December 11 To Monday, December 11
- AND search  OR search
- Customer name: Toshiba

**Figure 9.3.8**

#### 9.4. Deleting report data

Registered report data can be deleted. To erase report data, select the report data to be deleted and click the [Delete] button.



The screenshot shows the "Test report retrieve" window with a table of report data and search options. The "Delete" button is highlighted with a red box and labeled "Delete button".

Report No.	Report type	System name or No	Project/Site name	Customer name	Start date for test	Finish da
1	2	SMMS-I	2	SMMS-I	Toshiba	11/19/2012 11:29:01 AM 11/19/2012
2	4	SMMS-I	System Name	Project/Site	Customer	12/6/2012 7:14:39 PM 12/6/2012

Search condition:

- Report No. Report No. To
- If do not remember report No., pls click SEARCH with blank.

Other:

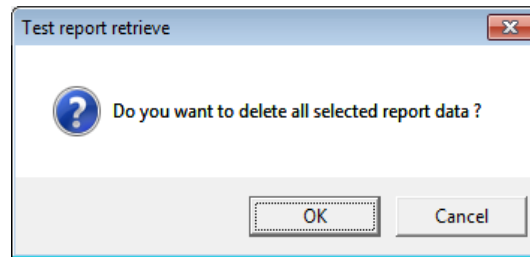
- Project/Site name
- AND search  OR search
- Start date for test: Monday, December 11 To Monday, December 11
- AND search  OR search
- Customer name

Buttons: Search, Delete, Cancel, Select

**Figure 9.4.1**

A delete confirmation message is displayed. Click the [OK] button to delete the data. Clicking the [OK] button deletes the report data from the database file.

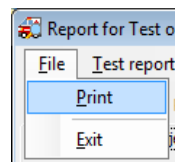




**Figure 9.4.2**

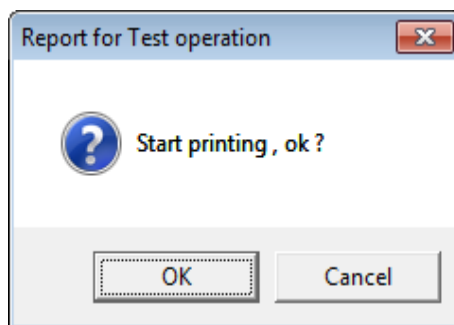
### 9.5. Printing out report data

Report data can be printed out. To print report data, select [Print...] from the [File] menu.



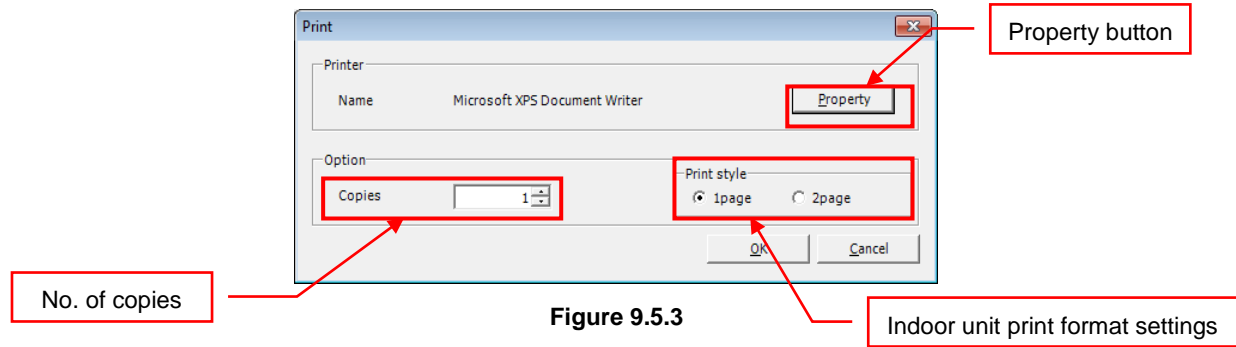
**Figure 9.5.1**

A start printing confirmation message is displayed. Click [OK] to start printing. The test operation report printing screen is displayed when the [OK] button is clicked.

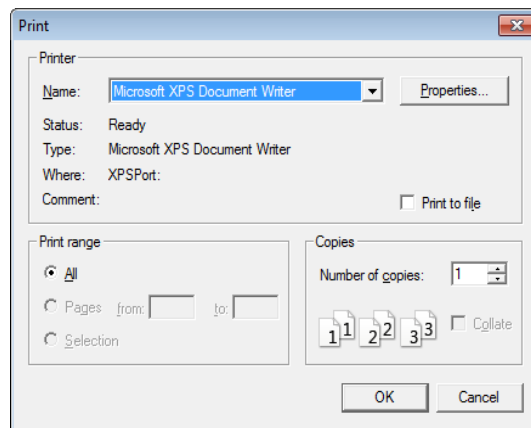


**Figure 9.5.2**

On the print screen, the printer settings, number of copies and printing format can be set. Click the [Property] button to change the printer settings. A print dialogue is displayed. The number of copies can also be input directly.



**Figure 9.5.3**



**Figure 9.5.4**

Click the [OK] button to print the test operation report.

## 10. TOSHIBA CARRIER SOFTWARE LICENSE AGREEMENT

IMPORTANT: PLEASE READ TERMS AND CONDITIONS OF THIS AGREEMENT CAREFULLY BEFORE USING “DynaDoctor V SOFTWARE” (HEREINAFTER CALLED “THE SOFTWARE”). BY USING OR INSTALLING A WHOLE OR A PART OF THIS SOFTWARE, YOU (HEREINAFTER CALLED “USER”) ARE DEEMED TO ACCEPT ALL THE TERMS AND CONDITIONS OF THIS AGREEMENT. IF USER DO NOT AGREE TO THESE TERMS AND CONDITIONS, DO NOT USE OR INSTALL THE SOFTWARE AND RETURN TO THE LOCATION FROM WHICH IT WAS OBTAINED.

1. For the purpose of this Agreement, “Software” means the computer programs and information and data (including without limitation electric documents) contained in the media or files distributed with this Agreement., except those specifically excluded not as a part of the software in writing.
2. The Software is the property of Toshiba Carrier Corporation. Toshiba Carrier Corporation owns all intellectual properties in the software. User may use the Software only in accordance with the terms and conditions of this Agreement, and only for such purpose as designated by Toshiba Carrier Corporation or as agreed to by Toshiba Carrier Corporation.
3. Toshiba Carrier Corporation owns the copyright of the software and data in the software. The software is protected under applicable copyright law and international conventions.
4. User may copy and install this Software for such purpose as described in the documents of the Software. Any copy created by User shall be immediately destroyed immediately after necessity of such copy are ended. With an exception of the forgoing, User shall not make any copy of the Software;
5. User shall not reverse engineer, decompile, disassemble, or modify the Software.
6. User shall not use the software with plural people within any internal network or Internet.
7. User shall not distribute, transfer, rent, lease, or sell its right to use the Software to anyone.
8. User shall respect the intellectual property right of the software. User understand the confidential nature of the Software and agrees to safeguard the software from disclosure to any third party.
9. User shall comply with the Foreign Exchange and Foreign Trade Control Laws and other related export regulations applicable in Japan. User shall comply with the U.S Export Administration Regulations, export control laws and regulations of all other countries.

10. THIS SOFTWARE ARE PROVIDED "AS IS" WITHOUT ANY WARRANTY OF ANY KIND, EITHER EXPRESS OR IMPLIED, INCLUDING, BUT NOT LIMITED TO, THE IMPLIED WARRANTY AND FITNESS FOR A PARTICULAR PURPOSE. TOSHIBA CARRIER CORPORATION HEREBY DISCLAIMS ANY WARRANTIES RELATING TO QUALITY AND PERFORMANCE OF THE SOFTWARE. TOSHIBA CARRIER CORPORATION SHALL NOT BE LIABLE FOR ANY DAMAGES, LOSSES, EXPENSES OR COSTS, IF ANY, INCURRED IN CONNECTION WITH OR AS A RESULT OF THE USE OF THE SOFTWARE.

Toshiba Carrier Corporation reserve a right to make modification or improvement of the software at any time.

11. In the case of breach any terms and conditions of this Agreement, or this Agreement be terminated or expired, User shall de-install the Software, scrap the Software any/or return the media and/or the files of Software to Toshiba Carrier Corporation immediately, along with any remaining copies thereof.

12. Toshiba Carrier Corporation may request User to stop using the Software at any time upon notice to USER.

13. This Agreement are governed and construed by the laws of Japan.